

New install of EV-100 Evolution Pilot Revision B

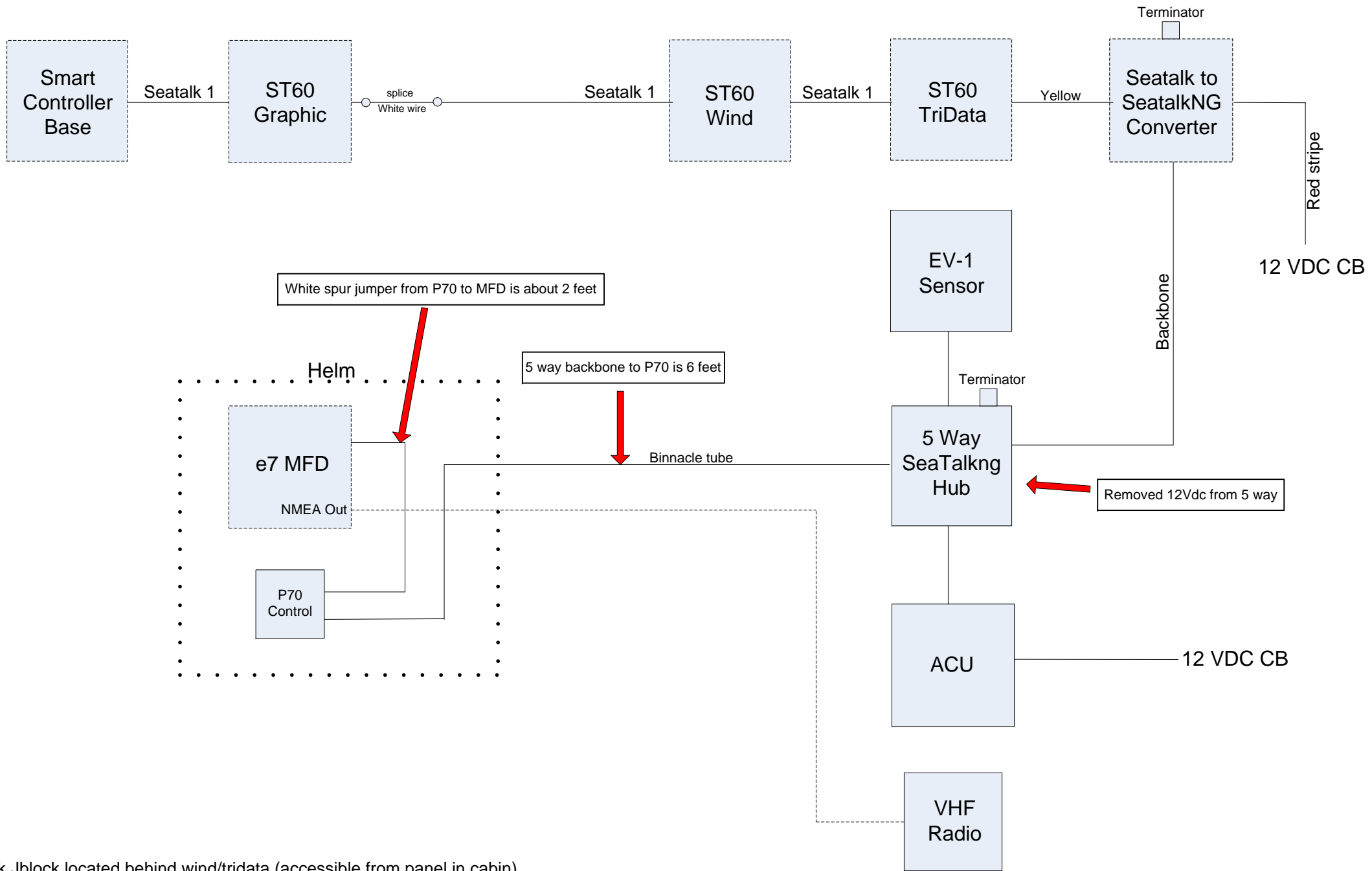

Notes-
 Seataalk Jblock located behind wind/tridata (accessible from panel in cabin)
 SeataalkNG converter located behind CB Panel
 Smart Pilot Controller Base located on top of Engine Panel rear cover shell

Dashed item = existing items, solid = new install