

# i70 Instrument

## INSTALLATION & OPERATION INSTRUCTIONS

English (EN)

Date: 05-2016

Document number: 81357-1

© 2016 Raymarine UK Limited



**Raymarine**<sup>®</sup>  
BY **FLIR**

# Printed Manuals

Would you prefer a printed version of this document?

Full documentation for your product is always provided as a free download on the Raymarine website, but some customers prefer manuals in a printed format.



Raymarine provides a Print Shop service which enables you to purchase a printed manual (paperback book), delivered to your door.

[www.raymarine.com/printshop](http://www.raymarine.com/printshop)



## Trademark and patents notice

**Raymarine, Tacktick, Clear Pulse, Truzoom, HSB, SeaTalk, SeaTalk<sup>hs</sup>, SeaTalk<sup>ng</sup>, Micronet, Raytech, Gear Up, Marine Shield, Seahawk, Autohelm, Automagic, and Visionality** are registered or claimed trademarks of Raymarine Belgium.

**FLIR, DownVision, SideVision, Dragonfly, Quantum, Instalert, Infrared Everywhere, and The World's Sixth Sense** are registered or claimed trademarks of FLIR Systems, Inc.

All other trademarks, trade names, or company names referenced herein are used for identification only and are the property of their respective owners.

This product is protected by patents, design patents, patents pending, or design patents pending.

## Fair Use Statement

You may print no more than three copies of this manual for your own use. You may not make any further copies or distribute or use the manual in any other way including without limitation exploiting the manual commercially or giving or selling copies to third parties.

## Software updates

**Important:** Check the Raymarine website for the latest software releases for your product.

[www.raymarine.com/software](http://www.raymarine.com/software)

## Product handbooks

The latest versions of all English and translated handbooks are available to download in PDF format from the website [www.raymarine.com](http://www.raymarine.com). Please check the website to ensure you have the latest handbooks.

**Copyright ©2016 Raymarine UK Ltd. All rights reserved.**



# Contents

## Chapter 1 Important information..... 9

TFT Displays .....	9
Water ingress .....	9
Disclaimer.....	10
EMC installation guidelines .....	10
Suppression ferrites .....	10
Connections to other equipment .....	10
Declaration of conformity.....	10
Product disposal.....	10
Warranty registration .....	10
IMO and SOLAS.....	10
Technical accuracy .....	11

## Chapter 2 Document and product information..... 13

2.1 Document information .....	14
Applicable products.....	14
Document illustrations.....	14
Product documentation .....	14
2.2 Product overview.....	14

## Chapter 3 Planning the installation..... 15

3.1 Installation checklist .....	16
Schematic diagram .....	16
3.2 Parts supplied.....	16
Compatible transducers .....	16
3.3 Software updates .....	17
3.4 Tools .....	17
3.5 Typical systems .....	18
3.6 System protocols.....	21
SeaTalkng®.....	21
NMEA 2000.....	21
SeaTalk .....	21
3.7 Warnings and cautions.....	21
3.8 General location requirements .....	22
Compass safe distance.....	22
Viewing angle considerations.....	22
3.9 Product dimensions.....	23

## Chapter 4 Cables and connections ..... 25

4.1 General cabling guidance.....	26
Cable types and length .....	26
Routing cables .....	26

Strain relief .....	26
Cable shielding.....	26
4.2 Connections overview .....	26
Connecting SeaTalkng® cables .....	26
SeaTalkng® product loading .....	26
4.3 SeaTalkng® power supply.....	27
SeaTalkng® power connection point .....	27
In-line fuse and thermal breaker ratings .....	27
SeaTalkng® system loading.....	27
Power distribution — SeaTalkng®.....	27
Sharing a breaker.....	28
4.4 Cable ferrite installation.....	29
4.5 SeaTalkng connection .....	30
4.6 NMEA 2000 network connection .....	31
4.7 SeaTalk connection .....	31
SeaTalk power protection.....	31
4.8 Transducer connections .....	32
iTC-5 connection .....	32
Transducer pod connection.....	32

## Chapter 5 Mounting..... 33

5.1 Mounting.....	34
Front bezel .....	34

## Chapter 6 Getting started ..... 35

6.1 Instrument controls.....	36
6.2 Power .....	36
Powering on the unit .....	36
Powering off the unit .....	36
6.3 Completing the startup wizard.....	37
6.4 Display settings .....	37
Adjusting the unit's brightness .....	37
Shared Brightness.....	37
Display response.....	38
6.5 Multiple data sources (MDS) overview .....	39
Selecting a preferred data source .....	39
6.6 Quick Options menu.....	40
Quick options menu items.....	40

## Chapter 7 Transducer calibration ..... 41

7.1 Transducer types.....	42	10.4 Viewing AIS target information.....	66
7.2 Depth calibration .....	42	10.5 Enabling and disabling AIS Silent mode .....	67
Depth Offset .....	42	<b>Chapter 11 Race timer settings .....</b>	<b>69</b>
Setting the depth offset .....	42	11.1 Setting the Race Timer .....	70
7.3 Speed calibration.....	43	11.2 Using the Race Timer .....	70
1 Point Speed Calibration .....	44	<b>Chapter 12 Instrument alarms .....</b>	<b>71</b>
Nautical measured mile markers.....	44	12.1 Alarms .....	72
Performing a Speed Run Calibration using SOG.....	45	Man over Board (MoB) alarm.....	72
Calibration Table .....	45	Alarm settings .....	72
Calibrating Water Temperature .....	48	<b>Chapter 13 Setup menu .....</b>	<b>75</b>
7.4 Wind calibration.....	48	13.1 Setup menu .....	76
Calibrating wind.....	48	Transducer setup menu .....	77
Aligning the wind transducer .....	48	User Preferences menu .....	79
Adjusting the wind transducer .....	49	System set-up menu .....	82
Adjusting apparent wind speed .....	49	Diagnostics menu.....	83
7.5 Rudder reference calibration .....	50	<b>Chapter 14 Maintenance .....</b>	<b>85</b>
Centering the Rudder.....	50	14.1 Service and maintenance.....	86
Adjusting the Rudder Angle .....	51	14.2 Routine equipment checks .....	86
Inverting the Rudder.....	51	14.3 Product cleaning.....	87
7.6 Compass calibration.....	51	14.4 Cleaning the display case .....	87
Swinging the Compass .....	51	14.5 Cleaning the display screen .....	88
Setting the Compass Offset .....	52	Transducer care and cleaning.....	88
<b>Chapter 8 Favorite Pages .....</b>	<b>53</b>	14.6 Cleaning the sun cover.....	88
8.1 Favorite pages.....	54	<b>Chapter 15 System checks and troubleshooting .....</b>	<b>89</b>
Selecting pages.....	54	15.1 Troubleshooting.....	90
8.2 Customizing pages .....	54	15.2 Power up troubleshooting.....	91
Editing an existing page .....	54	15.3 System data troubleshooting.....	92
Adding a page .....	54	15.4 Miscellaneous troubleshooting.....	93
Deleting a page .....	55	15.5 Performing a Factory Reset .....	94
Changing the page order .....	55	<b>Chapter 16 Technical support .....</b>	<b>95</b>
Setting page Rollover.....	55	16.1 Raymarine product support and servicing .....	96
Resetting accumulative data.....	55	16.2 Viewing product information .....	97
<b>Chapter 9 Data (Quick View).....</b>	<b>57</b>	<b>Chapter 17 Technical specification .....</b>	<b>99</b>
9.1 Data items .....	58	17.1 Technical specification.....	100
9.2 Viewing Data (Quick View).....	60	<b>Chapter 18 Options and accessories .....</b>	<b>101</b>
9.3 Adding a Quick View as a Favorite page .....	61	18.1 Spares and accessories.....	102
<b>Chapter 10 AIS.....</b>	<b>63</b>		
10.1 AIS Overview.....	64		
10.2 AIS target symbols .....	65		
10.3 Setting AIS Range.....	66		

18.2 Smart transducers .....	102
18.3 Instrument Depth, Speed and Temperature (DST) transducers.....	103
18.4 Instrument Depth transducers.....	104
18.5 Instrument Speed and Temperature transducers .....	104
18.6 Instrument Wind Vane transducer .....	105
18.7 Instrument Rotavecta transducer .....	105
18.8 Other transducers.....	106
18.9 SeaTalk <sup>ng</sup> ® cables and accessories .....	106
18.10 SeaTalk <sup>ng</sup> cable kits.....	108
18.11 SeaTalk accessories.....	111

**Appendix A Supported NMEA 2000  
PGN list.....113**





## Chapter 1: Important information



### Warning: Product installation and operation

- This product must be installed and operated in accordance with the instructions provided. Failure to do so could result in personal injury, damage to your vessel and/or poor product performance.
- Raymarine recommends certified installation by a Raymarine approved installer. A certified installation qualifies for enhanced product warranty benefits. Contact your Raymarine dealer for further details, and refer to the separate warranty document packed with your product.



### Warning: Potential ignition source

This product is NOT approved for use in hazardous/flammable atmospheres. Do NOT install in a hazardous/flammable atmosphere (such as in an engine room or near fuel tanks).



### Warning: Product grounding

Before applying power to this product, ensure it has been correctly grounded, in accordance with the instructions provided.



### Warning: Positive ground systems

Do not connect this unit to a system which has positive grounding.



### Warning: Switch off power supply

Ensure the vessel's power supply is switched OFF before starting to install this product. Do NOT connect or disconnect equipment with the power switched on, unless instructed in this document.



### Warning: Power supply voltage

Connecting this product to a voltage supply greater than the specified maximum rating may cause permanent damage to the unit. Refer to the *Technical specification* section for voltage rating.

### Caution: Power supply protection

When installing this product ensure the power source is adequately protected by means of a suitably-rated fuse or automatic circuit breaker.

### Caution: Sun covers

- If your product is supplied with a sun cover, to protect against the damaging effects of ultraviolet (UV) light, always fit the sun cover when the product is not in use.
- Sun covers must be removed when travelling at high speed, whether in water or when the vessel is being towed.

### Caution: Product cleaning

When cleaning products:

- If your product includes a display screen, do NOT wipe the screen with a dry cloth, as this could scratch the screen coating.
- Do NOT use abrasive, or acid or ammonia based products.
- Do NOT use a jet wash.

### Caution: Service and maintenance

This product contains no user serviceable components. Please refer all maintenance and repair to authorized Raymarine dealers. Unauthorized repair may affect your warranty.

## TFT Displays

The colors of the display may seem to vary when viewed against a colored background or in colored light. This is a perfectly normal effect that can be seen with all color Thin Film Transistor (TFT) displays.

## Water ingress

Water ingress disclaimer

Although the waterproof rating capacity of this product meets the stated IPX standard (refer to the product's *Technical Specification*), water intrusion and subsequent equipment failure may occur if the product is subjected to commercial high-pressure washing. Raymarine will not warrant products subjected to high-pressure washing.

## Disclaimer

Raymarine does not warrant that this product is error-free or that it is compatible with products manufactured by any person or entity other than Raymarine.

Raymarine is not responsible for damages or injuries caused by your use or inability to use the product, by the interaction of the product with products manufactured by others, or by errors in information utilized by the product supplied by third parties.

## EMC installation guidelines

Raymarine equipment and accessories conform to the appropriate Electromagnetic Compatibility (EMC) regulations, to minimize electromagnetic interference between equipment and minimize the effect such interference could have on the performance of your system

Correct installation is required to ensure that EMC performance is not compromised.

**Note:** In areas of extreme EMC interference, some slight interference may be noticed on the product. Where this occurs the product and the source of the interference should be separated by a greater distance.

For **optimum** EMC performance we recommend that wherever possible:

- Raymarine equipment and cables connected to it are:
  - At least 1m (3ft) from any equipment transmitting or cables carrying radio signals e.g. VHF radios, cables and antennas. In the case of SSB radios, the distance should be increased to 7 ft (2 m).
  - More than 2m (7ft) from the path of a radar beam. A radar beam can normally be assumed to spread 20 degrees above and below the radiating element.
- The product is supplied from a separate battery from that used for engine start. This is important to prevent erratic behavior and data loss which can occur if the engine start does not have a separate battery.
- Raymarine specified cables are used.
- Cables are not cut or extended, unless doing so is detailed in the installation manual.

**Note: Where constraints on the installation prevent any of the above recommendations,** always ensure the maximum possible separation between different items of electrical equipment, to provide the best conditions for EMC performance throughout the installation

## Suppression ferrites

- Raymarine cables may be pre-fitted or supplied with suppression ferrites. These are important for correct EMC performance. If ferrites are supplied

separately to the cables (i.e. not pre-fitted), you must fit the supplied ferrites, using the supplied instructions.

- If a ferrite has to be removed for any purpose (e.g. installation or maintenance), it must be replaced in the original position before the product is used.
- Use only ferrites of the correct type, supplied by Raymarine or its authorized dealers.
- Where an installation requires multiple ferrites to be added to a cable, additional cable clips should be used to prevent stress on the connectors due to the extra weight of the cable.

## Connections to other equipment

Requirement for ferrites on non-Raymarine cables

If your Raymarine equipment is to be connected to other equipment using a cable not supplied by Raymarine, a suppression ferrite **MUST** always be attached to the cable near the Raymarine unit.

## Declaration of conformity

Raymarine UK Ltd. declares that this product is compliant with the essential requirements of EMC directive 2004/108/EC.

The original Declaration of Conformity certificate may be viewed on the relevant product page at [www.raymarine.com](http://www.raymarine.com).

## Product disposal

Dispose of this product in accordance with the WEEE Directive.



The Waste Electrical and Electronic Equipment (WEEE) Directive requires the recycling of waste electrical and electronic equipment.

## Warranty registration

To register your Raymarine product ownership, please visit [www.raymarine.com](http://www.raymarine.com) and register online.

It is important that you register your product to receive full warranty benefits. Your unit package includes a bar code label indicating the serial number of the unit. You will need this serial number when registering your product online. You should retain the label for future reference.

## IMO and SOLAS

The equipment described within this document is intended for use on leisure marine boats and workboats NOT covered by International Maritime Organization (IMO) and Safety of Life at Sea (SOLAS) Carriage Regulations.

## Technical accuracy

To the best of our knowledge, the information in this document was correct at the time it was produced. However, Raymarine cannot accept liability for any inaccuracies or omissions it may contain. In addition, our policy of continuous product improvement may change specifications without notice. As a result, Raymarine cannot accept liability for any differences between the product and this document. Please check the Raymarine website ([www.raymarine.com](http://www.raymarine.com)) to ensure you have the most up-to-date version(s) of the documentation for your product.



## Chapter 2: Document and product information

### Chapter contents

- [2.1 Document information on page 14](#)
- [2.2 Product overview on page 14](#)

## 2.1 Document information

This document contains important information related to the installation of your Raymarine product.

The document includes information to help you:

- plan your installation and ensure you have all the necessary equipment;
- install and connect your product as part of a wider system of connected marine electronics;
- troubleshoot problems and obtain technical support if required.

This and other Raymarine product documents are available to download in PDF format from [www.raymarine.com](http://www.raymarine.com).

## Applicable products

This document is applicable to the following products:

	Part number	Name	Description
	E22172	i70	multifunction Instrument display

## Document illustrations

Your product may differ slightly from that shown in the illustrations in this document, depending on product variant and date of manufacture.

All images are provided for illustration purposes only.

## Product documentation

The following documentation is applicable to your product:

Description	Part number
<b>i70 Installation and operation instructions</b> Installation and operation instructions for the i70 unit and connection to a wider system of marine electronics.	81357
<b>i70 Mounting template</b> Mounting diagram for surface mounting a i70 unit.	87130

## Additional documentation

Description	Part number
<b>SeaTalkng® reference manual</b>	81300
<b>iTC-5 Installation instructions</b>	87138

## 2.2 Product overview

The i70 is a multifunctional instrument display with AIS capabilities. In conjunction with a compatible instrument transducer and an iTC-5, the i70 provides a detailed view of environmental, navigational and vessel data.

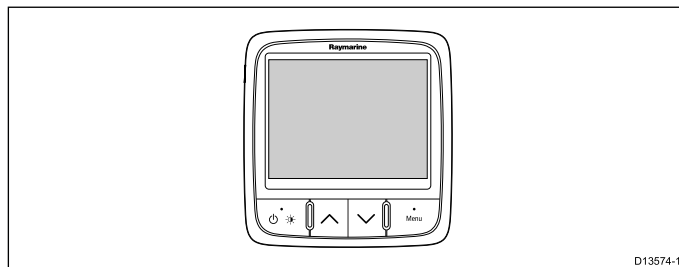

The i70 has the following features:

- 4.1" high brightness color LCD with wide viewing angles
- SeaTalkng®, NMEA 2000 and SeaTalk compatible
- Large clear characters (up to 43 mm / 1.7 in) for easy reading in any conditions
- Easy to use LightHouse™ operating system
- AIS repeater and display of AIS targets
- Data views include: Wind, Speed, Depth, Tridata, Engine, Environment, Fuel and Navigation
- 12V dc operation
- Low power consumption
- Waterproof to IPx6

# Chapter 3: Planning the installation

## Chapter contents

- [3.1 Installation checklist on page 16](#)
- [3.2 Parts supplied on page 16](#)
- [3.3 Software updates on page 17](#)
- [3.4 Tools on page 17](#)
- [3.5 Typical systems on page 18](#)
- [3.6 System protocols on page 21](#)
- [3.7 Warnings and cautions on page 21](#)
- [3.8 General location requirements on page 22](#)
- [3.9 Product dimensions on page 23](#)

### 3.1 Installation checklist

Installation includes the following activities:

Installation Task	
1	Plan your system.
2	Obtain all required equipment and tools.
3	Site all equipment.
4	Route all cables.
5	Drill cable and mounting holes.
6	Make all connections into equipment.
7	Secure all equipment in place.
8	Power on and test the system.

### Schematic diagram

A schematic diagram is an essential part of planning any installation. It is also useful for any future additions or maintenance of the system. The diagram should include:

- Location of all components.
- Connectors, cable types, routes and lengths.

### 3.2 Parts supplied

The following parts are supplied with your product.

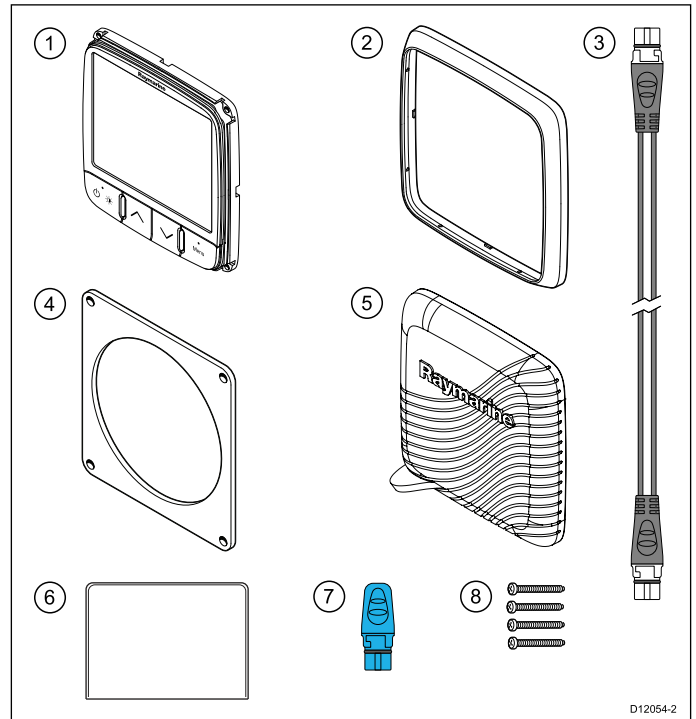

	Description
1	i70 Multifunction instrument display
2	Bezel
3	400 mm (15.8 in.) SeaTalkng® Spur Cable
4	Panel seal gasket
5	Suncover
6	Documentation pack
7	SeaTalkng® Blanking plug
8	4 x M3x16 pan head PZ screws

Unpack the unit carefully to prevent damage. Save the carton and packing in case the unit has to be returned for service.

### Compatible transducers

For a list of compatible transducers please refer to [Chapter 18 Options and accessories](#).



### 3.3 Software updates

The software running on the product can be updated.

- Raymarine periodically releases software updates to improve product performance and add new features.
- You can update the software for your product using a connected and compatible multifunction display.
- Refer to [www.raymarine.com/software/](http://www.raymarine.com/software/) for the latest software updates and the software update procedure for your product.
- If in doubt as to the correct procedure for updating your product software, refer to your dealer or Raymarine technical support.

#### Caution: Installing software updates

The software update process is carried out at your own risk. Before initiating the update process ensure you have backed up any important files.

Ensure that the unit has a reliable power supply and that the update process is not interrupted.

Damage caused by incomplete updates are not covered by Raymarine warranty.

By downloading the software update package, you agree to these terms.

### 3.4 Tools

#### Tools required for installation

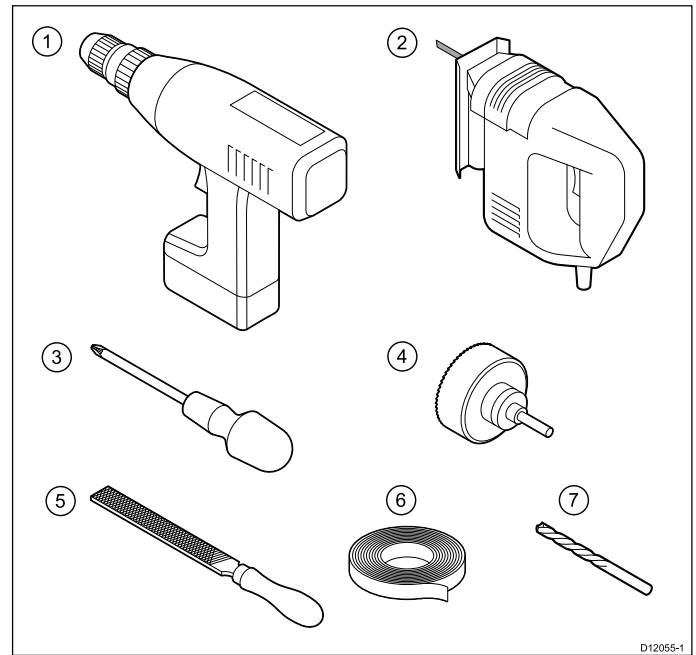

1.	Power drill
2.	Jig saw
3.	Screwdriver
4.	Suitable size (10 mm to 30 mm) hole cutter
5.	File
6.	Adhesive tape
7.	Drill bit of appropriate size <sup>(1)</sup>

**Note:** (1) Drill bit size is dependent on the thickness and type of material that the unit is to be mounted on.

### 3.5 Typical systems

The following illustrations show the products that can be connected in a typical system.

#### Example: Simple environmental data system

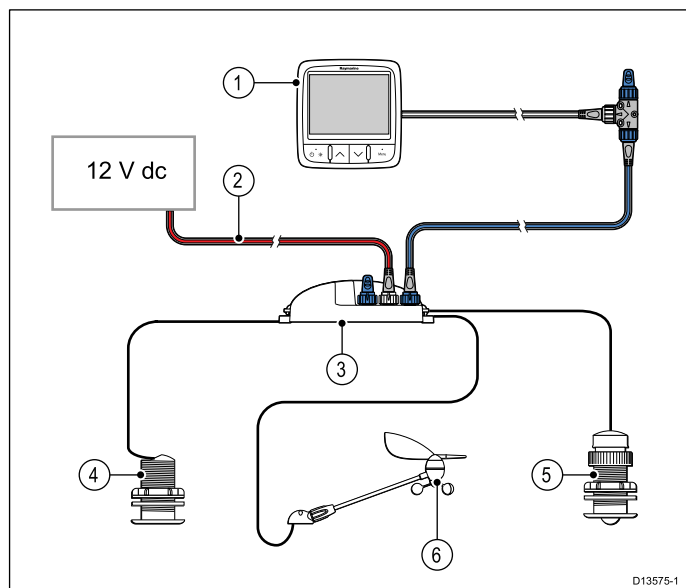

D13575-1

Item	Description
1	Instrument display (e.g. i70)
2	SeaTalkng® 12 V dc power supply
3	iTC-5 converter
4	Depth transducer (Analog)
5	Speed / Temperature transducer (Analog)
6	Wind transducer (Analog)

## Example: Expanded system without autopilot

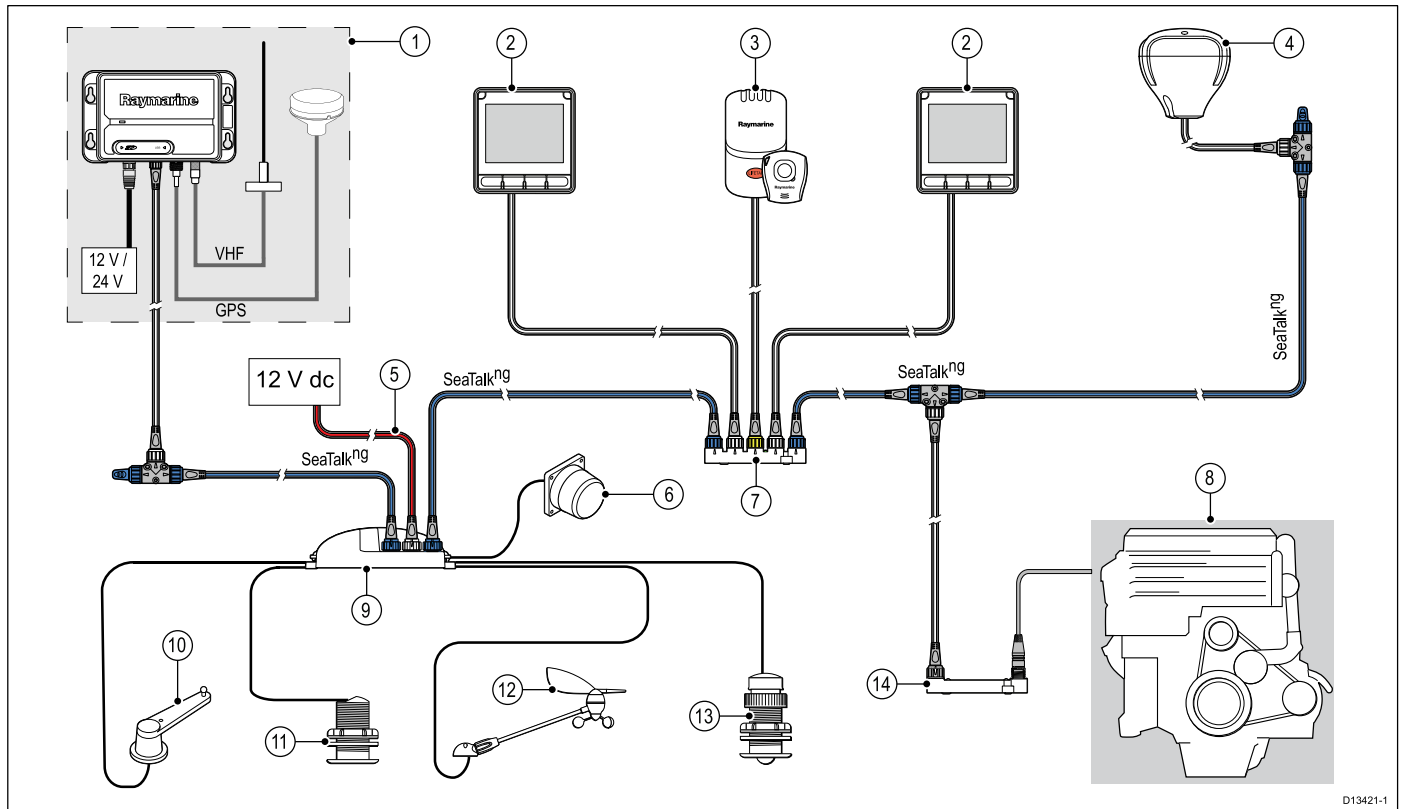

D13421-1

Item	Description
1	AIS receiver / transceiver (AIS350 / AIS650)
2	Instrument display (e.g. i70)
3	Life Tag — Man Over Board (MOB) system
4	SeaTalkng® GPS/GNSS Receiver (e.g. RS130)
5	SeaTalkng® 12 V dc power supply
6	Fluxgate compass
7	SeaTalk to SeaTalkng® converter
8	Vessel / Engine systems
9	iTC-5 converter
10	Rudder reference
11	Depth transducer (Analog)
12	Wind transducer (Analog)
13	Speed / Temperature transducer (Analog)
14	ECI-100

**Note:** Depending on engine type, it may be possible to connect the engine system directly to the SeaTalkng® backbone using a SeaTalkng® to DeviceNet adaptor cable. Without using the ECI-100 the available data will be limited to supported, standard NMEA 2000 data only.

## Example: Expanded system with autopilot

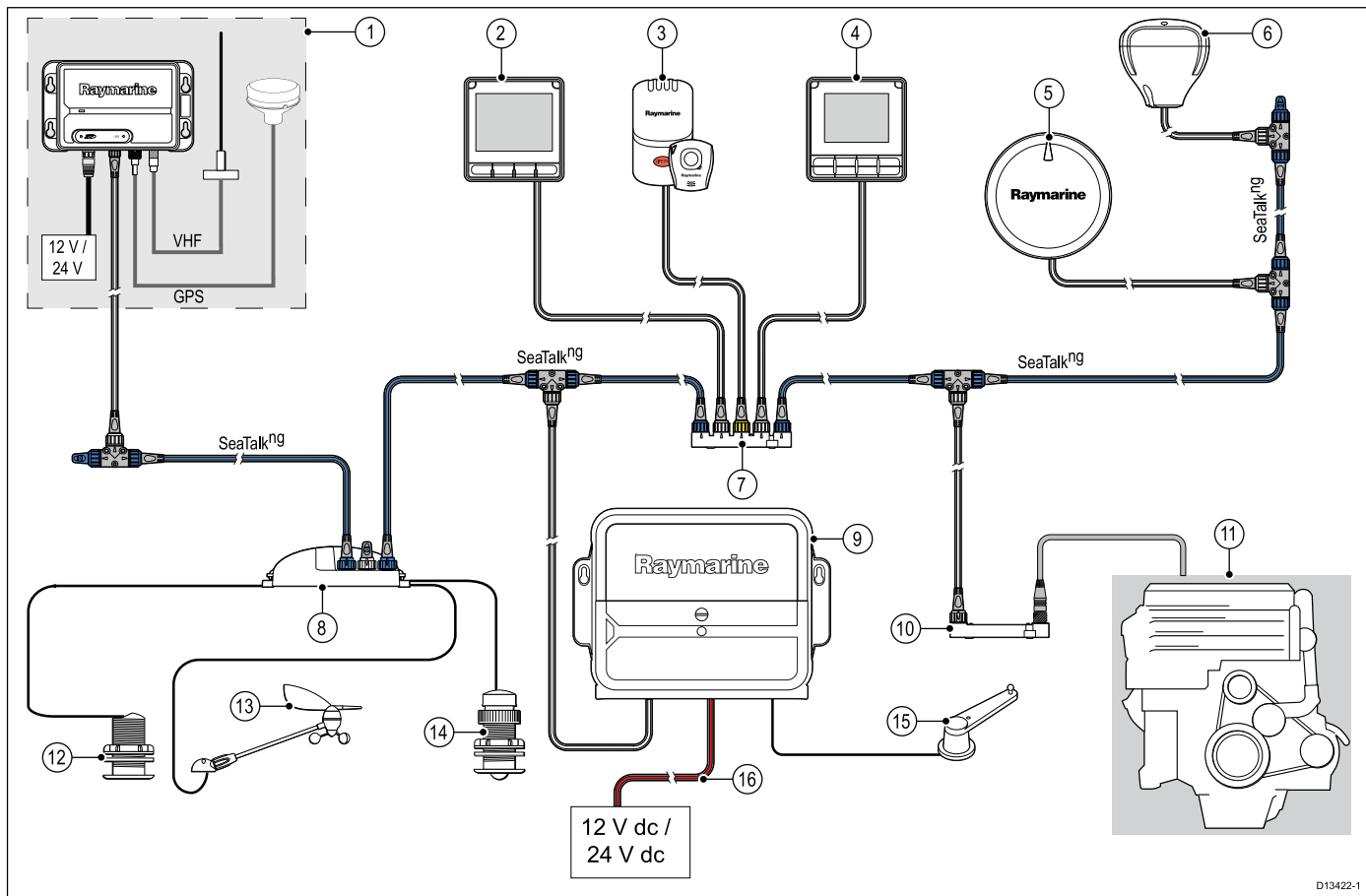

D13422-1

Item	Description
1	AIS receiver / transceiver (AIS350 / AIS650)
2	Instrument display (e.g. i70)
3	Life Tag — Man Over Board (MOB) system
4	Pilot Controller (e.g. p70 or p70R)
5	Evolution™ Autopilot
6	SeaTalkng® GPS/GNSS Receiver (e.g. RS130)
7	SeaTalk to SeaTalkng® converter
8	iTC-5 converter
9	ACU (Autopilot Control Unit)
10	ECI-100
	<p><b>Note:</b> Depending on engine type, it may be possible to connect the engine system directly to the SeaTalkng® backbone using a SeaTalkng® to DeviceNet adaptor cable. Without using the ECI-100 the available data will be limited to supported, standard NMEA 2000 data only.</p>
11	Vessel / Engine systems
12	Depth transducer (Analog)
13	Wind transducer (Analog)
14	Speed / Temperature transducer (Analog)
15	Rudder reference
16	12 V dc / 24 V dc power supply (powering the SeaTalkng® backbone.)

## 3.6 System protocols

Your product can be connected to various products and systems to share information and so improve the functionality of the overall system.

These connections may be made using a number of different protocols. Fast and accurate data collection and transfer is achieved by using a combination of the following data protocols:

- **SeaTalkng®**
- **NMEA 2000**
- **SeaTalk**

**Note:** You may find that your system does not use all of the connection types or instrumentation described in this section.

### SeaTalkng®

SeaTalkng® (Next Generation) is an enhanced protocol for connection of compatible marine instruments and equipment. It replaces the older SeaTalk and SeaTalk2 protocols.

SeaTalkng® utilizes a single backbone to which compatible equipment connect using a spur. Data and power are carried within the backbone. Devices that have a low draw can be powered from the network, although high current equipment will need to have a separate power connection.

SeaTalkng® is a proprietary extension to NMEA 2000 and the proven CAN bus technology. Compatible NMEA 2000 and SeaTalk and SeaTalk2 devices can also be connected using the appropriate interfaces or adaptor cables as required.

### NMEA 2000

**NMEA 2000** offers significant improvements over **NMEA 0183**, most notably in speed and connectivity. Up to 50 units can simultaneously transmit and receive on a single physical bus at any one time, with each node being physically addressable. The standard was specifically intended to allow for a whole network of marine electronics from any manufacturer to communicate on a common bus via standardized message types and formats.

### SeaTalk

**SeaTalk** is a protocol which enables compatible instruments to connect to each other and share data.

The **SeaTalk** cable system is used to connect compatible instruments and equipment. The cable carries power and data and enables connection without the need for a central processor.

Additional instruments and functions can be added to a **SeaTalk** system, simply by plugging them into the network. **SeaTalk** equipment can also communicate with other non-SeaTalk equipment via the **NMEA 0183** standard, provided a suitable interface is used.

## 3.7 Warnings and cautions

**Important:** Before proceeding, ensure that you have read and understood the warnings and cautions provided in the [Chapter 1 Important information](#) section of this document.

## 3.8 General location requirements

Important considerations when choosing a suitable location for your product.

This product is suitable for mounting above or below decks.

The product should be mounted where it will be:

- protected from physical damage and excessive vibration.
- well ventilated and away from heat sources.
- away from any potential ignition source such as an engine room, near fuel tanks or a gas locker.

When choosing a location for the product, consider the following points to ensure reliable and trouble-free operation:

- **Access** — there must be sufficient space to enable cable connections to the product, avoiding tight bends in the cable.
- **Diagnostics** — the product must be mounted in a location where the diagnostics LED is easily visible.

**Note:** Not all products include a diagnostics LED. Refer to the [Chapter 15 System checks and troubleshooting](#) for more information.

- **Electrical interference** — the product should be mounted far enough away from any equipment that may cause interference such as motors, generators and radio transmitters / receivers.
- **Magnetic compass** — refer to the *Compass safe distance* section in this document for advice on maintaining a suitable distance between this product and any compasses on your vessel.
- **Power** — to keep cable runs to a minimum, the product must be located as close as possible to the vessel's dc power supply.
- **Mounting surface** — ensure the product is adequately supported on a secure surface. Refer to the weight information provided in the *Technical specification* for this product and ensure that the intended mounting surface is suitable for bearing the product weight. Do NOT mount units or cut holes in places which may damage the structure of the vessel.

### Compass safe distance

To prevent potential interference with the vessel's magnetic compasses, ensure an adequate distance is maintained from the product.

When choosing a suitable location for the product you should aim to maintain the maximum possible distance from any compasses. Typically this distance should be at least 1 m (3 ft) in all directions. However for some smaller vessels it may not be possible to locate the product this far away from a compass. In this situation, when choosing the installation location for your product, ensure that the compass is not affected by the product when it is in a powered state.

## Viewing angle considerations

As display contrast, color and night mode performance are all affected by the viewing angle, Raymarine recommends you temporarily power up the display when planning the installation, to enable you to best judge which location gives the optimum viewing angle.

### 3.9 Product dimensions

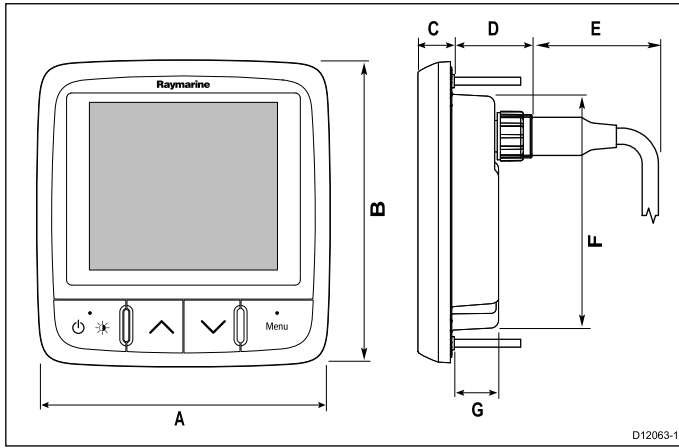

Item	Description
A.	110 mm (4.33")
B.	115 mm (4.52")
C.	14 mm (0.55")
D.	30 mm (1.18")
E.	35 mm (1.38")
F.	90 mm (3.54")
G.	17 mm (0.67")





# Chapter 4: Cables and connections

## Chapter contents

- [4.1 General cabling guidance on page 26](#)
- [4.2 Connections overview on page 26](#)
- [4.3 SeaTalkng® power supply on page 27](#)
- [4.4 Cable ferrite installation on page 29](#)
- [4.5 SeaTalkng connection on page 30](#)
- [4.6 NMEA 2000 network connection on page 31](#)
- [4.7 SeaTalk connection on page 31](#)
- [4.8 Transducer connections on page 32](#)

## 4.1 General cabling guidance

### Cable types and length

It is important to use cables of the appropriate type and length

- Unless otherwise stated use only standard cables of the correct type, supplied by Raymarine.
- Ensure that any non-Raymarine cables are of the correct quality and gauge. For example, longer power cable runs may require larger wire gauges to minimize voltage drop along the run.

### Routing cables

Cables must be routed correctly, to maximize performance and prolong cable life.

- Do NOT bend cables excessively. Wherever possible, ensure a minimum bend diameter of 200 mm (8 in) / minimum bend radius of 100 mm (4 in).

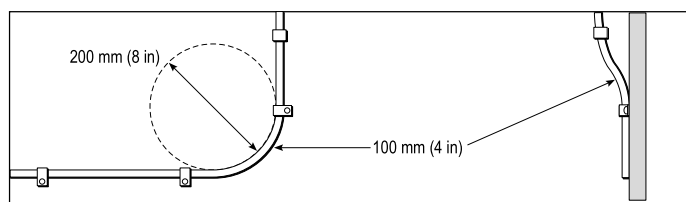

- Protect all cables from physical damage and exposure to heat. Use trunking or conduit where possible. Do NOT run cables through bilges or doorways, or close to moving or hot objects.
- Secure cables in place using tie-wraps or lacing twine. Coil any extra cable and tie it out of the way.
- Where a cable passes through an exposed bulkhead or deckhead, use a suitable watertight feed-through.
- Do NOT run cables near to engines or fluorescent lights.

Always route data cables as far away as possible from:

- other equipment and cables,
- high current carrying AC and DC power lines,
- antennae.

### Strain relief

Ensure adequate strain relief is provided. Protect connectors from strain and ensure they will not pull out under extreme sea conditions.

### Cable shielding

Ensure that all data cables are properly shielded that the cable shielding is intact (e.g. hasn't been scraped off by being squeezed through a tight area).

## 4.2 Connections overview

Use the following information to help you identify the connections on your product.

Connector	Qty	Connects to:	Suitable cables
	2	<ol style="list-style-type: none"> <li>1. SeaTalkng® backbone</li> <li>2. NMEA 2000 backbone</li> <li>3. SeaTalk backbone</li> <li>4. SeaTalkng® device</li> </ol>	<ol style="list-style-type: none"> <li>1. SeaTalkng® spur cables</li> <li>2. SeaTalkng® to DeviceNet adaptor cable (A06045)</li> <li>3. SeaTalk to SeaTalkng® adaptor cable (A06073)</li> </ol>

### Connecting SeaTalkng® cables

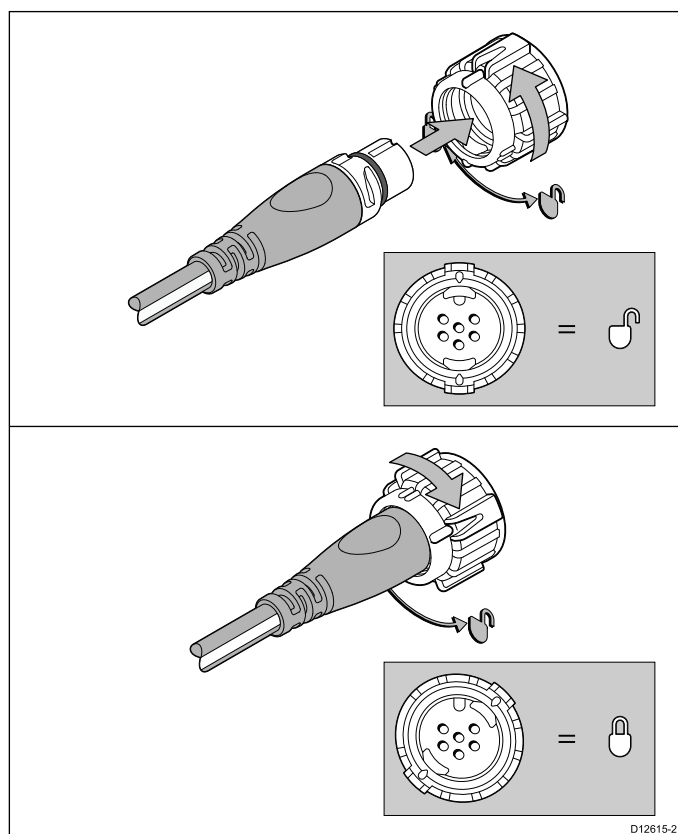

1. Rotate the locking collar on the unit to the unlocked position.
2. Ensure the cable's connector is correctly oriented.
3. Fully insert the cable connector.
4. Rotate locking collar clockwise (2 clicks) until it is in the locked position.

### SeaTalkng® product loading

The number of products that can be connected to a SeaTalkng® backbone depends on the power consumption of each product and the physical overall length of the backbone.

SeaTalkng® products have a Load Equivalency Number (LEN), which indicates the product's power consumption. The LEN for each product can be found in the product's Technical Specification.

## 4.3 SeaTalkng® power supply

Power is supplied to the product over the SeaTalkng® backbone.

A SeaTalkng® backbone requires one 12 V dc power supply, connected to the SeaTalkng® backbone. This can be provided by:

- a battery <sup>(1)</sup>, via the distribution panel,
- an Autopilot Control Unit (ACU)<sup>(2)</sup>,
- an SPX course computer <sup>(2)</sup>,
- for 24 V vessels a 5 amp, regulated, continuous 24 V dc to 12 V dc converter is required.

### Note:

- (1) The battery used for starting the vessel's engine(s) should NOT be used to power the SeaTalkng® backbone as this can cause sudden voltage drops, when the engines are started.
- (2) The ACU-100 and SPX-5 cannot be used to power the SeaTalkng® backbone.

## SeaTalkng® power connection point

### Small systems

If the backbone length is 60 m (197 ft) or less, the power connection point may be connected at any point in the backbone.

### Large systems

If the backbone length is greater than 60 m (197 ft), the power connection point should be connected at a point that creates a balanced current draw from each side of the backbone. The Load Equivalency Number (LEN) is used to determine the power connection point for the system.

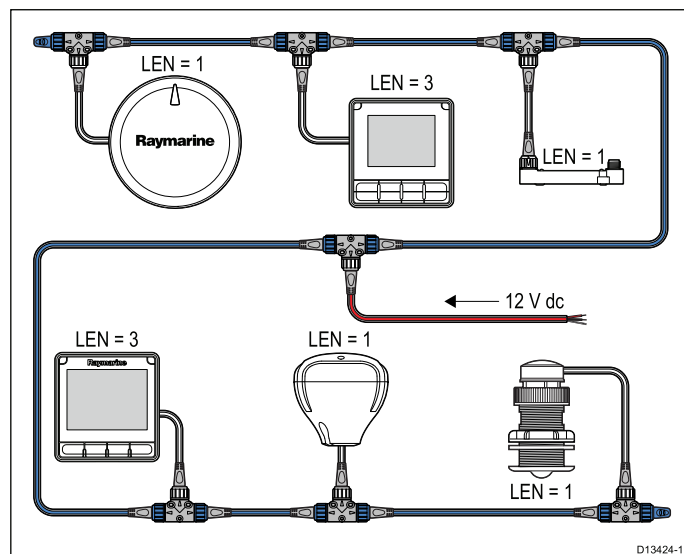

In the example above the system has an overall LEN of 10, so the optimum connection point would be to have 5 LEN either side of the connection point.

## In-line fuse and thermal breaker ratings

The SeaTalkng® network's power supply requires an in-line fuse or thermal breaker to be fitted.

In-line fuse rating	Thermal breaker rating
5A	3 A (if only connecting one device)

**Note:** The suitable fuse rating for the thermal breaker is dependent on the number of devices you are connecting. If in doubt consult an authorized Raymarine dealer.

## SeaTalkng® system loading

The maximum loading / LEN for a SeaTalkng® system depends on the length of the backbone.

Loading type	Backbone length	Total LEN
Unbalanced	20 m (66 ft)	40
Unbalanced	40 m (131 ft)	20
Unbalanced	60 m (197 ft)	14
Balanced	60 m (197 ft) or less	100
Balanced	80 m (262 ft)	84
Balanced	100 m (328 ft)	60
Balanced	120 m (394 ft)	50
Balanced	140 m to 160 m (459 ft to 525 ft)	40
Balanced	180 m to 200 m (591 ft to 656 ft)	32

## Power distribution — SeaTalkng®

Recommendations and best practice.

- Only use approved SeaTalkng® power cables. Do NOT use a power cable designed for, or supplied with, a different product.
- See below for more information on implementation for some common power distribution scenarios.

**Important:** When planning and wiring, take into consideration other products in your system, some of which (e.g. sonar modules) may place large power demand peaks on the vessel's electrical system.

**Note:** The information provided below is for guidance only, to help protect your product. It covers common vessel power arrangements, but does NOT cover every scenario. If you are unsure how to provide the correct level of protection, please consult an authorized Raymarine dealer or a suitably qualified professional marine electrician.

### Implementation — direct connection to battery

- SeaTalkng® power cables may be connected directly to the vessel's battery, via a suitably rated fuse or breaker.

- You **MUST** fit a suitably rated fuse or breaker between the red wire and the battery's positive terminal.
- Refer to the inline fuse ratings provided in the product's documentation.
- If you need to extend the length of the power cable, ensure you use suitably rated cable and that sufficient power (12 V dc) is available at the SeaTalkng® backbone's power connection.

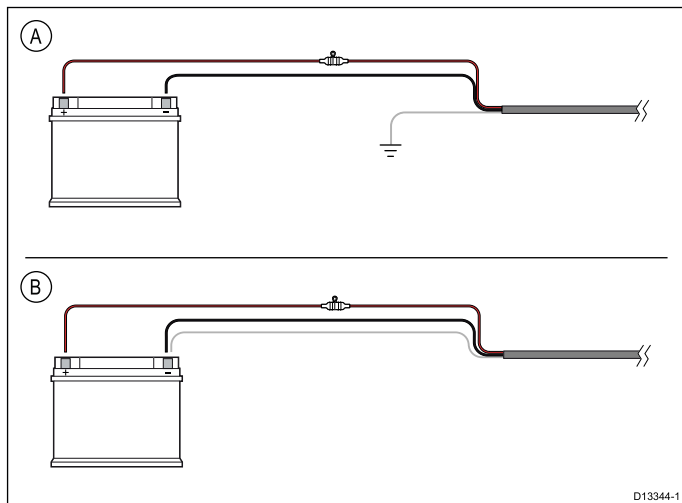

A	Battery connection scenario A: suitable for a vessel with a common RF ground point. In this scenario, if your product's power cable is supplied with a separate drain wire then it should be connected to the vessel's common ground point.
B	Battery connection scenario B: suitable for a vessel without a common grounding point. In this case, if your product's power cable is supplied with a separate drain wire then it should be connected directly to the battery's negative terminal.

### Implementation — connection to distribution panel

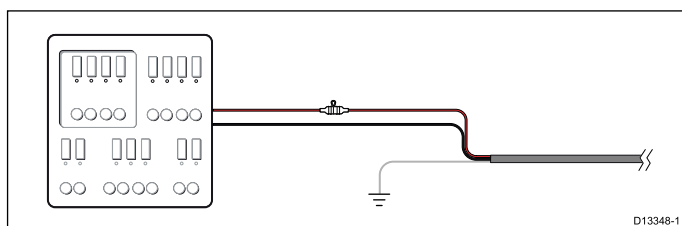

- Alternatively, the SeaTalkng® power cable may be connected to a suitable breaker or switch on the vessel's distribution panel or factory-fitted power distribution point.
- The distribution point should be fed from the vessel's primary power source by 8AWG (8.36mm<sup>2</sup>) cable.
- Ideally, all equipment should be wired to individual suitably-rated thermal breakers or fuses, with appropriate circuit protection. Where this is not possible and more than 1 item of equipment shares a breaker, use individual in-line fuses for each power circuit to provide the necessary protection.
- In all cases, observe the recommended breaker / fuse ratings provided in the product's documentation.

- If you need to extend the length of the power cable, ensure you use suitably rated cable and that sufficient power (12 V dc) is available at the SeaTalkng® backbone's power connection.

**Important:** Be aware that the suitable fuse rating for the thermal breaker or fuse is dependent on the number of devices you are connecting.

### More information

Raymarine recommends that best practice is observed in all vessel electrical installations, as detailed in the following standards:

- BMEA Code of Practice for Electrical and Electronic Installations in Boats
- NMEA 0400 Installation Standard
- ABYC E-11 AC & DC Electrical Systems on Boats
- ABYC A-31 Battery chargers and Inverters
- ABYC TE-4 Lightning Protection

### Sharing a breaker

Where more than 1 piece of equipment shares a breaker you must provide protection for the individual circuits. E.g. by connecting an in-line fuse for each power circuit.

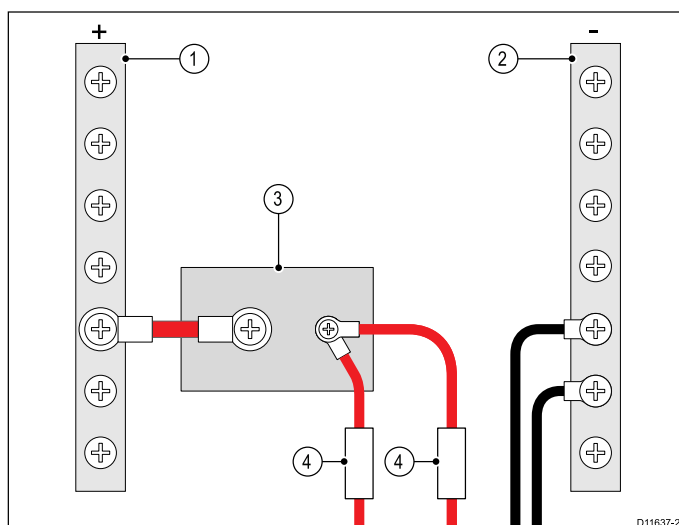

1	Positive (+) bar
2	Negative (-) bar
3	Circuit breaker
4	Fuse

Where possible, connect individual items of equipment to individual circuit breakers. Where this is not possible, use individual in-line fuses to provide the necessary protection.



### Warning: Product grounding

Before applying power to this product, ensure it has been correctly grounded, in accordance with the instructions provided.



### Warning: Positive ground systems

Do not connect this unit to a system which has positive grounding.

## 4.4 Cable ferrite installation

Your product is supplied with a cable ferrite. To ensure EMC Compliance, the supplied ferrite must be fitted to the cable according to the following instructions.

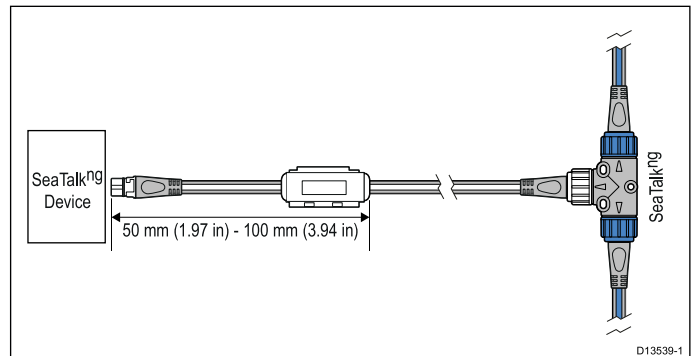

1. The ferrite must be fitted to the end of the cable closest to the device.
2. The ferrite must be fitted at the distance specified in the illustration above.
3. Ensure a tight and secure fit so that the ferrite will not move up or down the cable.

## 4.5 SeaTalk<sup>ng</sup> connection

**Note:** In the example below, if an **ACU-100** was used, the SeaTalk<sup>ng</sup> network would require a dedicated 12 V dc power supply because the **ACU-100** does not supply power to the SeaTalk<sup>ng</sup> network.

### Example: SeaTalk<sup>ng</sup> Evolution system with iTC-5

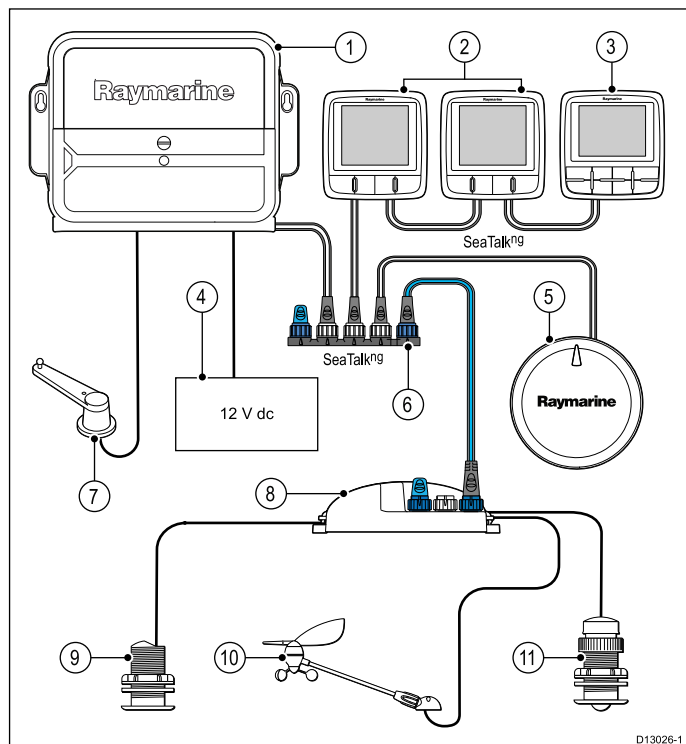

D13026-1

1	ACU unit
2	2 x Instruments
3	Pilot controller
4	Vessel's 12 V dc power supply
5	EV unit
6	SeaTalk <sup>ng</sup> 5-way connector
7	Rudder reference transducer
8	iTC-5 converter
9	Depth transducer
10	Wind transducer
11	Speed transducer

### Example: SeaTalk<sup>ng</sup> SPX system with transducer pods

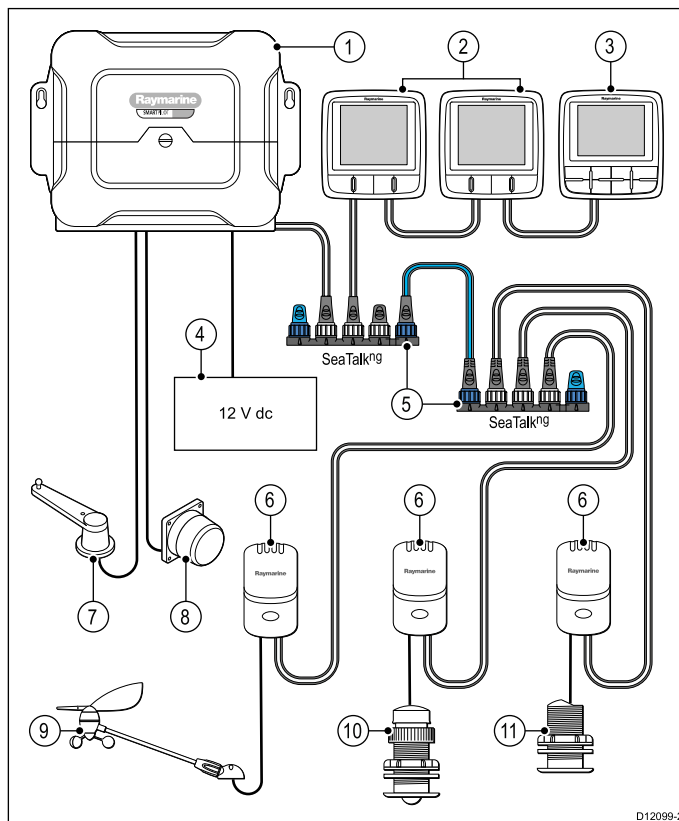

D12099-2

Item	Description
1	SPX (supplying 12V to SeaTalk <sup>ng</sup> network.)
2	2 x Instruments
3	p70 / p70R Pilot controller
4	Vessel's 12 V dc power supply
5	SeaTalk <sup>ng</sup> 5-way connectors with terminators
6	Transducer pods
7	Rudder reference transducer
8	Fluxgate compass
9	Wind transducer
10	Speed transducer
11	Depth transducer

## 4.6 NMEA 2000 network connection

Your **SeaTalk<sup>ng</sup>**® device can be connected to a **DeviceNet / NMEA 2000** network.

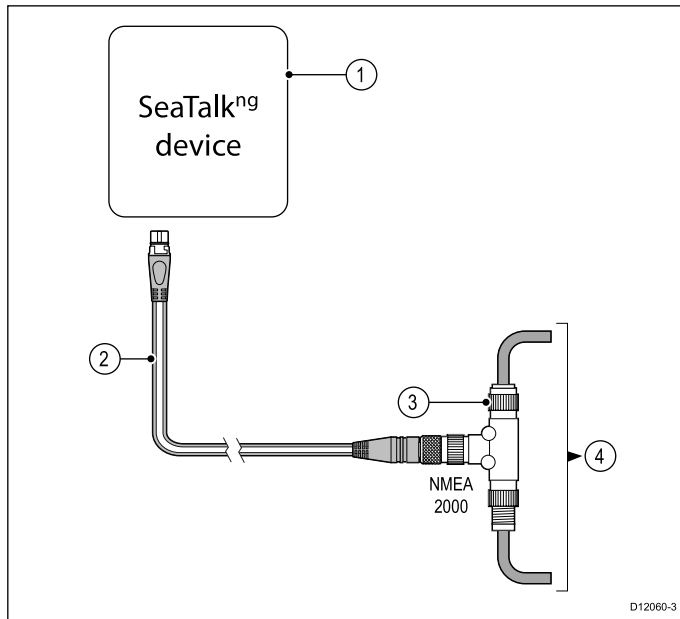

1. **SeaTalk<sup>ng</sup>**® device
2. **SeaTalk<sup>ng</sup>**® to **DeviceNet** adaptor cable (A06045)
3. **DeviceNet** T-piece
4. **NMEA 2000** backbone

## 4.7 SeaTalk connection

Connections to a SeaTalk network are made using a SeaTalk to SeaTalk<sup>ng</sup> adaptor cable (not supplied).

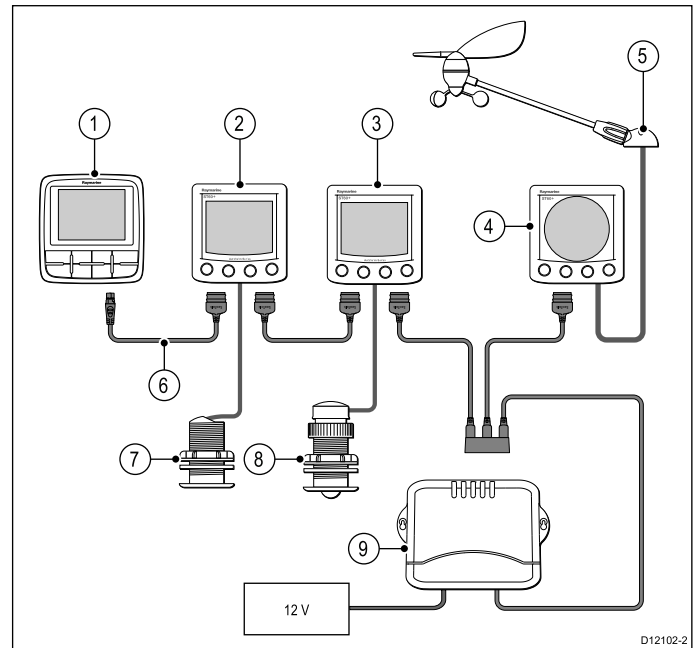

Item	Description
1.	p70 Pilot controller
2.	ST60+ Depth instrument
3.	ST60+ Speed instrument
4.	ST60+ Wind instrument
5.	Wind transducer
6.	SeaTalk <sup>ng</sup> to SeaTalk Adaptor cable
7.	Depth transducer
8.	Speed transducer
9.	Course computer (supplying 12V to SeaTalk network.)

For SeaTalk cables and extensions, use Raymarine SeaTalk cable accessories.

### SeaTalk power protection

The power supply must be protected by a 5 A fuse or a circuit breaker providing equivalent protection.

Raymarine recommends that the power is connected to a SeaTalk system in such a way that the current drawn on each side of the power connection point is equal.

## 4.8 Transducer connections

### iTC-5 connection

For details on connecting an **iTC-5** to the **SeaTalk<sup>ng</sup>**® backbone and connecting transducers to the **iTC-5**, refer to the documentation provided with your **iTC-5**.

### Transducer pod connection

Transducer pods are available for wind, depth and speed transducers. For detailed installation instructions, refer to documentation supplied with your pod.

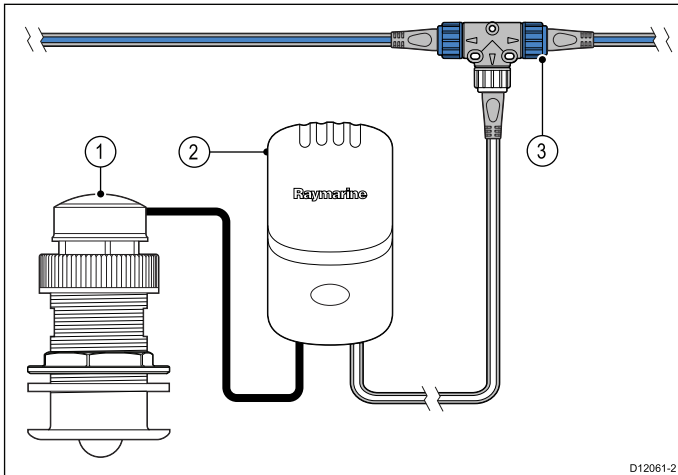

Item	Description
1	Speed and Temperature transducer
2	Speed pod
3	<b>SeaTalk<sup>ng</sup></b> ® T-Piece connector

1. Connect the transducer to the pod, the pod terminals are color-coded, ensure that each wire is connected to the corresponding terminal.
2. Connect the pod to the **SeaTalk<sup>ng</sup>**® backbone using a **SeaTalk<sup>ng</sup>**® spur cable and T-piece. Pods must be located no further than 400 mm (15.75 in.) from the connection point on the backbone



## Chapter 5: Mounting

### Chapter contents

- [5.1 Mounting on page 34](#)

## 5.1 Mounting

The product is designed to be flush mounted.

Before mounting the unit, ensure that you have:

- Selected a suitable location.
- Identified the cable connections and route that the cable will take.
- Detached the front bezel.

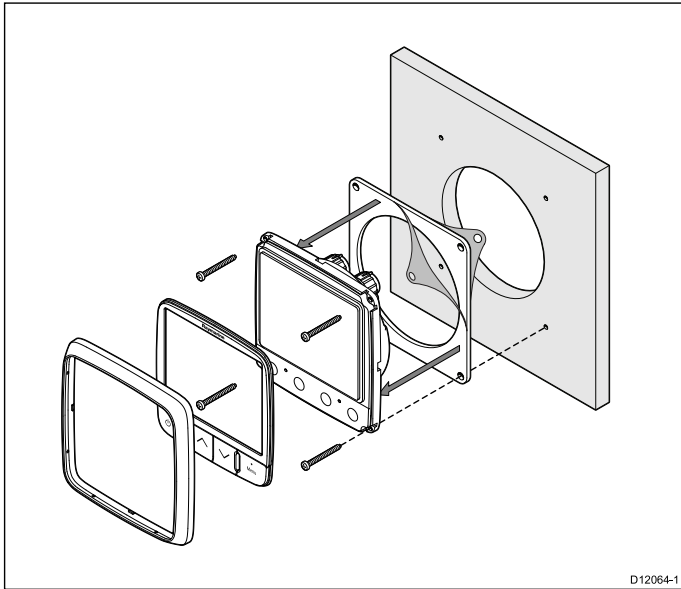

1. Check the selected location for the unit. A clear, flat area with suitable clearance behind the panel, is required.
2. Fix the appropriate cutting template supplied with the product, to the selected location, using masking or self-adhesive tape.
3. Using a suitable hole saw, make a pilot holes in each corner of the cut-out area.
4. Using a suitable saw, cut along the inside edge of the cut-out line.
5. Ensure that the unit fits into the removed area and then file around the cut edge until smooth.
6. Drill four holes as indicated on the template to accept the securing screws.
7. Peel the backing off of the gasket, and place the adhesive side of the gasket onto the display unit and press firmly onto the flange.
8. Connect cables to the unit.
9. Slide the unit into place and secure using screws provided.

**Note:** Drill, and tap size and tightening torque is dependent on the material type and thickness the unit is to be mounted on.

## Front bezel

### Removing the front bezel

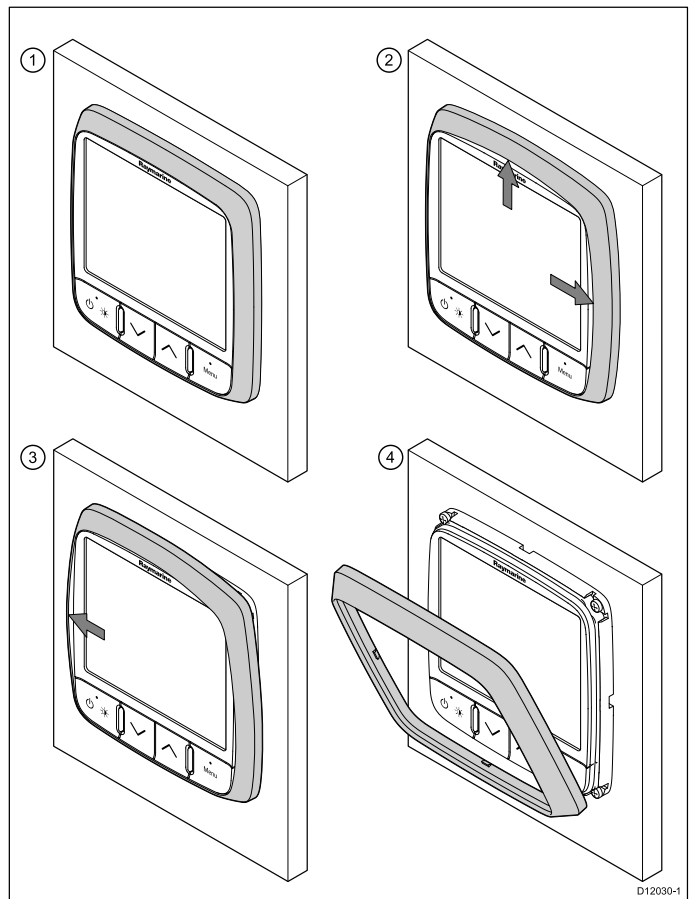

**Important:** Use care when removing the bezel. Do not use any tools to lever the bezel, doing so may cause damage.

1. Using your fingers pull the bezel away from the unit at the top and side, as shown in 2. The bezel will start to come away from the unit at the top and side.
2. Now pull the bezel away from the unit on the opposite side, as shown in 3. The bezel will now come free from the unit, as shown in 4.

# Chapter 6: Getting started

## Chapter contents

- [6.1 Instrument controls on page 36](#)
- [6.2 Power on page 36](#)
- [6.3 Completing the startup wizard on page 37](#)
- [6.4 Display settings on page 37](#)
- [6.5 Multiple data sources \(MDS\) overview on page 39](#)
- [6.6 Quick Options menu on page 40](#)

## 6.1 Instrument controls

Control layout and functions.

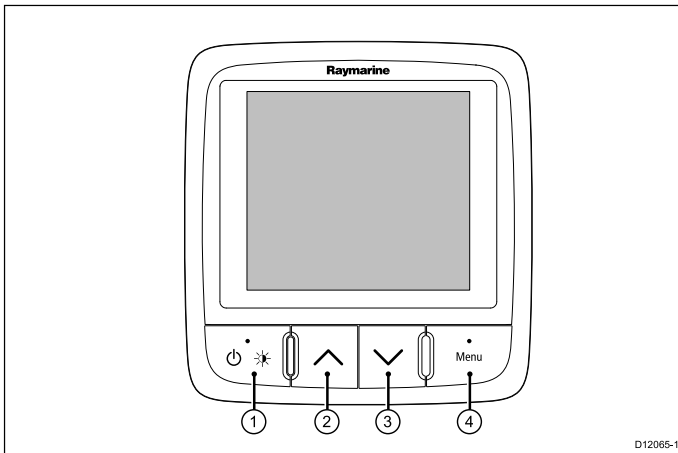

Item	Description
1.	<b>LEFT SOFT BUTTON</b> Power, brightness, cancel, back
2.	<b>UP ARROW</b> Up navigation, Adjust Up
3.	<b>DOWN ARROW</b> Down navigation, Adjust Down
4.	<b>RIGHT SOFT BUTTON</b> Menu, select, OK, Save

## 6.2 Power

### Powering on the unit

The unit will automatically turn on with the system, unless it has previously been powered off using the **Power** button.

With the unit powered off:

1. Press and hold the **Power** button until the screen turns on (approximately 2 seconds).

### Powering off the unit

1. Press and hold the **Power** button until the count down timer reaches zero and the screen turns off.

**Note:** When powered off, the unit may still draw a small amount of power from the battery, if this is a concern unplug the power supply or switch off at the breaker.

## 6.3 Completing the startup wizard

When you power-up the unit for the first time or after a system reset the Startup Wizard is displayed.

The setup wizard guides your through the following basic configuration settings:

1. Language
2. Boat Type
3. Welcome

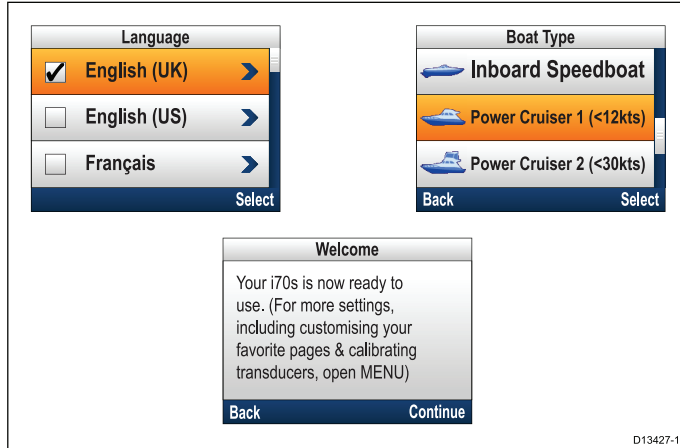

1. Using the **Up** and **Down** buttons, highlight the user interface Language that you want to use and then press the **Menu** button to confirm the selection.
2. Using the **Up** and **Down** buttons, highlight the Boat Type that you want to use and then press the **Menu** button to confirm the selection.  
The Welcome page is displayed.
3. Select **Continue**.  
The first of a pre-defined set of Favorite pages is displayed.

**Note:** The Startup Wizard may not be displayed if these settings have already been set on the system that the unit is connected to.

## 6.4 Display settings

### Adjusting the unit's brightness

To adjust the unit's LCD brightness level, when it is not part of a Shared Brightness group follow the steps below.

1. Press the **Power** button.  
The Display Brightness page is displayed.
2. Use the **Up** and **Down** buttons to adjust the brightness to the required level.
3. Select **Ok**.

*The Display Brightness page will time-out after 2 seconds, saving the new brightness level.*

### Shared Brightness

You can set up Shared Brightness groups which enables simultaneous brightness adjustment the all units that are part of the same group.

The following products are compatible with Shared Brightness:

- **LightHouse™** powered MFDs
- **SeaTalkng®** Instrument displays and Pilot controllers
- **Ray50 / Ray52 / Ray60 / Ray70** VHF DSC Radios

Any adjustments to the Shared Brightness level will be reflected on all units assigned to the same group.

LightHouse™ MFD	Instrument display / Pilot Controller
<b>Ray50 / Ray52 / Ray60 / Ray70</b> VHF DSC Radio	

Multiple brightness groups can be configured. These groups could be used to reflect the physical location of units on your vessel. For example, the units at your helm can be set to one group, and the units on the flybridge can be set to a different group.

Shared Brightness requires:

- all units to be compatible with the Shared Brightness function (see list of compatible units above).
- the **Share brightness** setting set to On for all units in the brightness group.
- units to be assigned to Network Groups.

- all the displays in that group to be synchronized.

### Assigning A Network Group

To enable the Shared Brightness and Color, unit's must be assigned to the same network group.

Compatible Instrument Displays and Pilot Controllers will also share their Color Scheme.

From the Network Group menu: (**Menu > Set-up > System Set-up > Network Group**)

1. Select the Network Group that you want to assign the unit to.

A list of network groups will be displayed:

- None (default)
- Helm 1
- Helm 2
- Cockpit
- Flybridge
- Mast
- Group 1 — Group 5

2. Select **Brightness/Color Group**.
3. Select **This Group**.
4. Select **Sync**.

*The System will now synchronize all units assigned to the same group.*

5. Select **OK**.
6. Carry out steps 1 to 5 on all unit's.

*The location of the Shared Brightness menu on **LightHouse™** MFDs is: (**Homescreen > Customize > Display Preferences > Shared Brightness**)*

Adjusting the Brightness level will now effect all units assigned to the same group.

### Unsharing a unit

Instrument Displays and Pilot Controllers can be removed from the Shared Brightness.

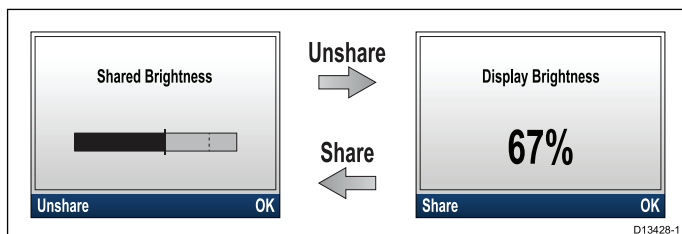

1. Press the **Power** button to display the Shared Brightness page.
2. Select **Unshare**.

*Selecting **Share** from the Display Brightness page will switch back to Shared Brightness.*

### Changing the color scheme

From the colors menu: (**Menu > Display Settings > Colors**)

1. Select a color scheme from the list

- Day 1
- Day 2
- Inverse
- Red/Black

If the unit is part of a network group, the color scheme selected will change on all units that support color schemes and are part of the same group.

### Display response

#### Setting the Display Response

Setting the Display Response to a low value will dampen data fluctuations to provide a more stable reading. Setting the Display Response to a high value will reduce then damping to make readings more responsive.

From the Display Settings menu: (**Menu > Display Settings** )

1. Select **Display Response**.
2. Select the data type:
  - Speed
  - Depth
  - Wind speed
  - Wind angle
  - Heading
3. Adjust the value as required.
4. Select **Save**.

## 6.5 Multiple data sources (MDS) overview

When a system includes multiple instances of a data source the preferred data source is selected automatically. The systems preferred source may not be your preferred source, or if you are experiencing a data conflict you can manually select your preferred data source.

MDS enables you to choose a preferred source for the following data types:

- GPS Position
- GPS Datum
- Time & Date
- Heading
- Depth
- Speed
- Wind

This exercise would usually be completed as part of the initial installation, or when new equipment is added.

For MDS to be available all products in the system that use the data sources listed above, must be MDS-compliant. The system will report any products that are NOT MDS-compliant. It may be possible to upgrade the software for these products, to make them compliant. Visit the Raymarine website ([www.raymarine.com](http://www.raymarine.com)) to obtain the latest software for your products.

If MDS-compliant software is not available for the product and you do NOT want to use the systems preferred data source, you must remove any non-compliant product from the system. You should then be able to select your preferred data source.

**Note:** Once you have completed setting up your preferred data sources, you may be able to add the non-compliant products back into the system.

### Selecting a preferred data source

From the System Set-up menu: (**Menu > Set-up > System Set-up**)

1. Select **Data Sources**.
2. Select the Data type.

*The unit will now search for and display a list of all sources for the selected data type.*

Depth	
<input checked="" type="checkbox"/>	<b>Auto</b>
<input type="checkbox"/>	00380016 STng - ACTIVE <b>ST70 Depth Pod</b>
<input type="checkbox"/>	00420065 STng <b>iTC-5 Converter</b>
<b>Back</b>	<b>Select</b>

3. Select your preferred data source, or
4. Select **Auto** to allow the system to decide.

*ACTIVE is displayed next to the data source that is the current source for the data type.*

## 6.6 Quick Options menu

The **Quick Options** menu (**Menu > Quick Options**) is a dynamic menu that displays menu items relative to the data displayed on the current Favorite page or Quick View page being viewed.

### Quick options menu items

Depending on the page being displayed different quick options are available as follows:

Page displayed	Quick options available
Menu	Edit page
MOB (when MOB is active)	MOB
Maximum depth	Reset Maximum Depth
Minimum depth	Reset Minimum Depth
Maximum speed	Reset Maximum Speed
Average speed	Reset Average Speed
Trip	Reset Trip
Max. SOG	Reset Max. SOG
Ave. SOG	Reset Ave. SOG
CMG & DMG	Reset CMG & DMG
Maximum Sea Temperature	Reset Max. Sea Temperature
Minimum Sea Temperature	Reset Min. Sea Temperature
Maximum Air Temperature	Reset Max. Air Temperature
Minimum Air Temperature	Reset Min. Air Temperature
Maximum AWA	Reset Maximum. AWA
Minimum AWA	Reset Minimum. AWA
Maximum AWS	Reset Max. AWS
Minimum AWS	Reset Min. AWS
Maximum TWA	Reset Max. TWA
Minimum TWA	Reset Min. TWA
Maximum TWS	Reset Max. TWS
Minimum TWS	Reset Min. TWS
Race Timer	Start timer
	Stop timer
	Reset timer
	Adjust start times
Graph	Time scale
(View data) page	Add to favorites
AIS	View AIS targets — (Only shown if there is Heading or stable COG data available.)
	AIS range
	AIS Silent mode



# Chapter 7: Transducer calibration

## Chapter contents

- 7.1 Transducer types on page 42
- 7.2 Depth calibration on page 42
- 7.3 Speed calibration on page 43
- 7.4 Wind calibration on page 48
- 7.5 Rudder reference calibration on page 50
- 7.6 Compass calibration on page 51

## 7.1 Transducer types

The transducers listed in the table below can be calibrated using the display.

Transducer type	Connection
Depth transducers	connected via <b>iTC-5</b> or Depth pod
Speed and temperature transducers	connected via <b>iTC-5</b> or Speed pod
Wind transducers	connected via <b>iTC-5</b> or Wind pod
Smart transducers	connected directly to <b>SeaTalk<sup>ng</sup></b>
Fluxgate compass	connected via <b>iTC-5</b>
Rudder reference	connected via <b>iTC-5</b>

## 7.2 Depth calibration

### Depth Offset

Depths are measured from the transducer to the bottom, you can apply an offset value to the depth data, so that the displayed depth reading represents the depth to the bottom from either the keel (negative offset) or the waterline (positive offset).

Before attempting to set a waterline or keel offset, find out the vertical separation between the transducer and either the waterline or the bottom of your vessel's keel, as appropriate. Then set the appropriate depth offset value.

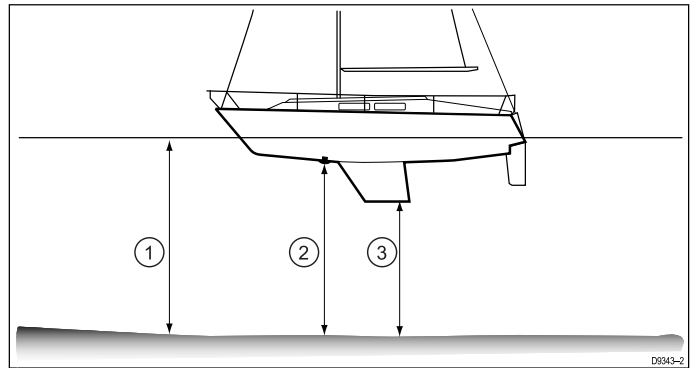

1	Waterline offset	Values greater than zero (Positive values) represent a waterline offset
2	Transducer	Zero offset represents the depth from the transducer's location
3	Keel offset	Values less than zero (Negative values) represent a keel offset

### Setting the depth offset

The depth calibration consists of setting a Depth Offset that is relevant to your depth transducer's installed location.

From any favorite page:

1. Select **Menu**.
2. Select **Set-up**.
3. Select **Transducers Set-up**.
4. Select **Continue**.

The instrument display will search for and display a list of connected devices. (i.e. iTC-5, DST or transducer pod)

5. Select the device that the transducer(s) you are calibrating are connected to.

A list of available transducer data is displayed,

6. \* Select **Depth**.

**Important:** \* Step only applicable to iTC-5.

7. Select **Depth Offset**.
8. Select **Depth From:**

A list of transducer offsets is displayed:

- Waterline
- Keel
- Transducer (default)

9. Select the location that you want depth measurements to be taken from.  
After selection the Depth Offset page is displayed. If you have selected Waterline or Keel a Depth Offset must be applied.
10. Select **Offset**:
11. Use the **Up** and **Down** buttons to adjust the Depth Offset to the required value.  
The offset value should be the same as the measured distance:
  - from the transducer face to the Waterline, or
  - from the transducer face to the bottom of the Keel.
12. Select **Save**.

Setting an incorrect Depth Offset could lead to your vessel running aground.

## 7.3 Speed calibration

Speed transducer calibration is required as transducer performance is affected by a number of variables such as transducer location, shape of the hull and water flow characteristics. The purpose of performing Speed calibration is to ensure that the speed readings at the instrument are a true indication of the vessel's actual speed.

In order to achieve accurate results, speed calibration must be carried out in calm conditions with zero tide and zero current.

Speed calibration aligns the instruments log speed (Speed Through Water) to:

- Speed Over Ground (SOG), or
- a referenced speed

### Calibrating using SOG

For most installations a 1 Point Speed Calibration is all that is required.

If the 1 point calibration does not provide sufficiently accurate readings or you require a higher level of precision for your speed readings then a Speed Run Calibration can be carried out. It is advisable to carry out the Speed Run Calibration at as many speeds as possible. This is particularly important for planing vessels.

\* Conventional speed transducers have a maximum of 5 calibration speeds, and smart transducers (e.g. DST800) have up to 8.

If required each calibration point can also have a calibration factor applied to further align the log speed reading across different vessel speeds.

**Note:** \* The Speed Run Calibration cannot be performed when the transducer is connected to a Speed Pod.

### Calibrating without SOG

For most installations a 1 Point Speed Calibration is all that is required. The calibration must be performed using a way of estimating actual vessel speed and adjusting the displayed reading so that the log speed matches the your estimated speed.

If you do not have SOG data available then the Speed Run Calibration cannot be performed.

If required, further calibration points can be added and a calibration factor can be applied to further align the log speed with actual vessel speed.

	iTC-5		Smart (DST)		Speed pod	
	SOG	No SOG	SOG	No SOG	SOG	No SOG
1 point speed calibration	✓	✓	✓	✓	✓	✓
Speed run calibration	✓	✗	✓	✗	✗	✗
Manual calibration	✓	✓	✓	✓	✓	✓

# 1 Point Speed Calibration

For most installations a 1 Point Speed Calibration is all that is required.

Prerequisites:

- For best results SOG data should be available, or an alternative method of estimating vessel speed must be used (e.g. vessel speed can be estimated using [Nautical Measured Mile Markers](#) or similar landmarks of a known distance apart).
- You will need to be underway, with sufficient space to maneuver unhindered.
- In order to achieve accurate results, water conditions must be calm with zero tide and zero current.

From a favorite page:

1. Select **Menu**.
2. Select **Set-up**.
3. Select **Transducers Set-up**.
4. Select **Continue**.

The instrument display will search for and display a list of connected devices. (i.e. iTC-5, DST or transducer pod)

5. Select the device that the transducer(s) you are calibrating are connected to.  
A list of available transducer data is displayed,
6. \* Select **Speed**.

**Important:** \* Step only applicable to iTC-5.

7. Select **Speed Calibration**.
8. Select **Adjust speed up/down**.  
The 1 Point Speed Calibration page is displayed.

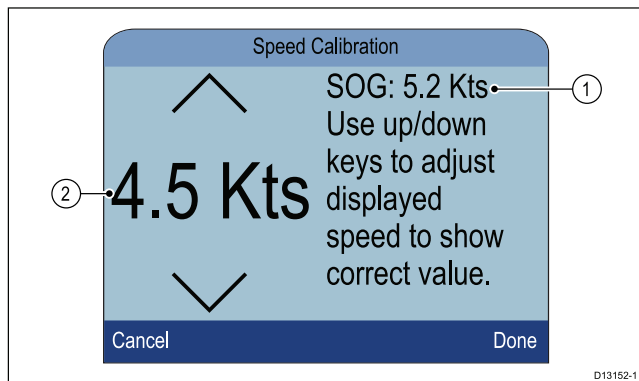

1. SOG speed reading
2. Current speed reading

If SOG is not available then the SOG value will display dashes.

9. Accelerate your vessel to a steady, typical cruising speed.
10. Use the **Up** and **Down** buttons to adjust the current speed reading so that it matches the SOG reading or matches your estimated speed.
11. Select **Done** when both values are the same.  
The calibration complete page is displayed.
12. Select **Ok**.

If you experience significant deviation between SOG and log speed readings at different vessel speeds

then a Speed Run Calibration should be performed. Refer to the [Performing a Speed Run Calibration using SOG](#) section for details.

## Nautical measured mile markers

When neither SOG data or any other reliable means of estimating Speed Through the Water (STW) is available, Nautical Measured Mile Markers can be used to help calibrate Log Speed. Nautical measured mile markers are identified by two pairs of posts or towers. The distance between each pair of markers is 1 nautical mile.

Each marker in a pair is separated by distance and elevation from its partner. The front marker is closer to the water and shorter than the marker behind it.

### Markers — side view

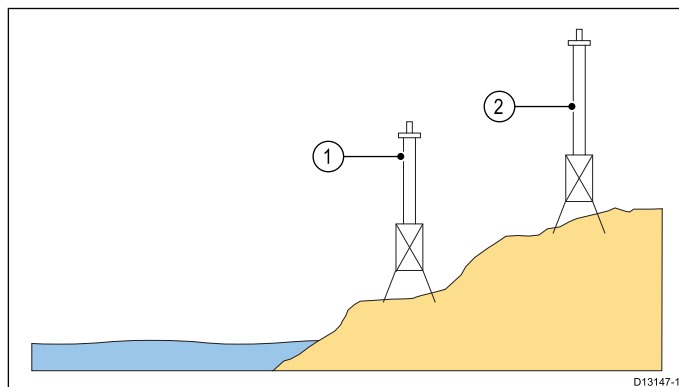

1. Front marker
2. Rear marker

When the 2 markers appear vertically aligned the vessel is on the correct range line to begin a measured mile run.

### Marker alignment

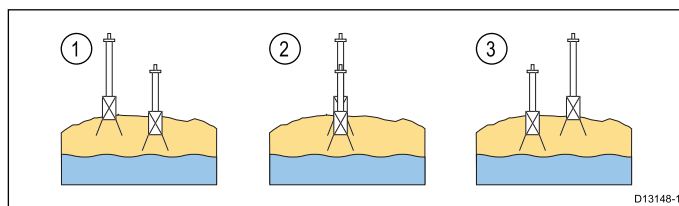

1. Left of range line
2. On range line
3. Right of range line

The vessel should already be at top speed and as the first pair of markers appear aligned a stopwatch should be started, when the vessel passes the second pair of aligned markers the stopwatch is stopped.

## Measuring a nautical mile

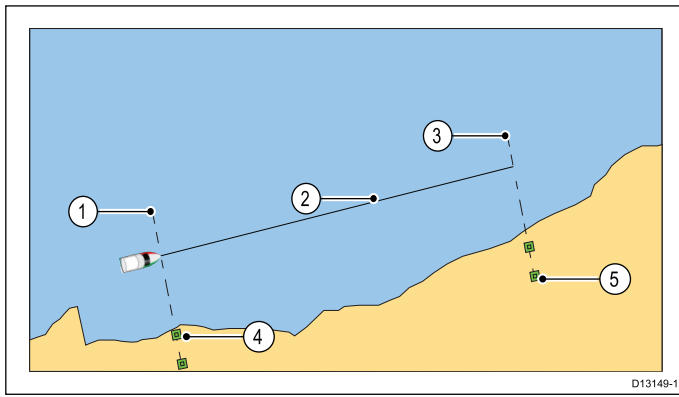

1. Starting point (start stopwatch)
2. Measured mile
3. End point (stop stopwatch)
4. First pair of markers
5. Second pair of markers

To provide a more accurate reading the vessel should make between 4 to 6 runs in both directions to allow for tide and wind conditions. The average of the time taken over all runs should be used to calculate Log Speed.

The vessel speed can then be worked out by taking the distance travelled (1 nautical mile) and dividing it by the average time taken to perform the run. The resulting calculation is your average speed in knots.

## Performing a Speed Run Calibration using SOG

If a higher level of precision is required than that achieved with the 1 Point Speed Calibration procedure, a Speed Run Calibration should be performed. The Speed Run Calibration will ensure that the Log Speed reading is accurate over the vessel's full speed range.

Prerequisites:

- SOG data must be available.
- You will need to be underway, with sufficient space to maneuver unhindered.
- In order to achieve accurate results, water conditions must be calm with zero tide and zero current.

**Note:** Speed Run Calibration is not available when connected to a Speed Pod.

The steps below detail the method of calibrating:

- speed transducers connected via an iTC-5
- the speed element of a smart transducer connected directly to the SeaTalk<sup>ng</sup> network.

From a favorite page:

1. Select **Menu**.
2. Select **Set-up**.
3. Select **Transducers Set-up**.
4. Select **Continue**.

The instrument display will search for and display a list of connected devices. (i.e. iTC-5, DST or transducer pod)

5. Select the device that the transducer(s) you are calibrating are connected to.  
A list of available transducer data is displayed,
6. \* Select **Speed**.

**Important:** \* Step only applicable to iTC-5.

7. Select **Speed Calibration**.
8. Select **New cal using SOG**.

You will need to add calibration points at a range of speeds spanning the full speed range of the vessel. Conventional transducers can have up to 5 calibration points and smart transducers can have up to 8. Ideally the calibration points should be taken at regular increments throughout the speed range with the last calibration point being close to the vessel's top speed.

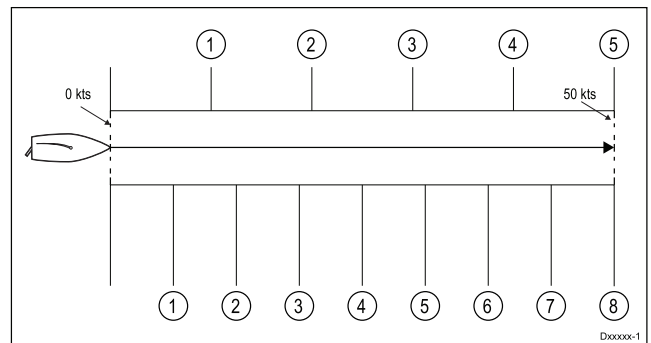

With the Speed Transducer connected to a Speed Pod the 5 calibration points are fixed in sequence at 2, 4, 8, 16 and 32 knots. When adding calibration points during the Speed Run Calibration ensure vessel speed is as close to the fixed calibration point speeds as possible, as the calibration factor applied will be the difference between the actual vessel speed and the fixed calibration point speed.

9. Select **Start**.
10. Ensure the vessel's speed is steady at your first calibration point speed and select **Add**.
11. Repeat step 10 for all remaining calibration points, ensuring that the calibration points are equally spaced throughout your vessel's speed range from stationary to top speed.  
Once all calibration points have been successfully added the Calibration complete message is displayed.
12. Select **Ok**.

## Calibration Table

By default Speed Transducers include a default set of calibration points which are overwritten during the normal speed calibration process. The calibration points are stored in the Calibration Table. The Calibration Table can be accessed from the Advanced Menu.

From the Advanced Menu you can:

- View the existing Calibration Table
- Adjust the existing calibration points (Add, Edit or Delete calibration points)
- Enter a new Calibration Table
- Check Log Speed against SOG

- Reset the Calibration Table to factory defaults

## Viewing the calibration Table

Calibration points are stored in the Calibration Table.

From a favorite page:

1. Select **Menu**.
2. Select **Set-up**.
3. Select **Transducers Set-up**.
4. Select **Continue**.

The instrument display will search for and display a list of connected devices. (i.e. iTC-5, DST or transducer pod)

5. Select the device that the transducer(s) you are calibrating are connected to.  
A list of available transducer data is displayed,
6. \* Select **Speed**.

**Important:** \* Step only applicable to iTC-5.

7. Select **Speed Calibration**.
8. Select **Advanced**.
9. Select **View cal table**.

The Calibration Table is displayed.

Uncal.	Factor	Calibrated
2.0Kts	x1.00	2.0Kts
4.0Kts	x1.00	4.0Kts
8.0Kts	x1.00	8.0Kts

PaddleWheel	Prev.	New
0.6 Hz	0.6 Kts	--
5.1 Hz	1.8 Kts	--
11.9 Hz	3.4 Kts	--

1. Speed transducer connected via iTC-5 or speed pod.
  2. Smart DST transducer connected directly to SeaTalk<sup>ng</sup>.
10. Use the **Up** and **Down** buttons to scroll up and down through the table.
  11. Select **Back** to return to the Advanced Menu.

## Checking speed

The current speed can be checked at any time from the Advanced Menu.

From the Advanced Menu:

1. Select **Check speed**.

The Check Speed page is displayed:

Speed	
Speed	7.5 Kts
SOG	8.0 Kts

OK

The Check Speed page can also be accessed from the Edit calibration options menu: **Advanced > Adjust cal table > Start > Options > Check speed**.

## Manually working out a Calibration Factor

New Calibration Factors can be worked out manually following the steps below.

- You will need to be underway, with sufficient space to maneuver unhindered.
  - To ensure accuracy, water conditions should be calm with zero tide and zero current.
  - You will need to calibrate each calibration speed point, starting with the lowest
1. In calm conditions with zero tide and zero current, run your vessel at a steady speed, approximately that of the selected calibration speed, over a measured distance.

Make a note of:

- The measured distance in nautical miles
  - The current speed value in knots
  - The time in minutes it takes to cover the measured distance
2. Calculate the actual speed over the measured distance using the calculation: (Speed = (60 x Distance) / Time) The '60' is used to ensure the calculation is in minutes rather than hours or tenths of an hour.

e.g. Distance = 14 nautical miles, Time = 105 minutes (1 hour 45 minutes) so:

- $S = (60 \times D) / T$
  - $S = (60 \times 14) / 105$
  - $S = 840 / 105$
  - $S = 8 \text{ Kts}$
3. If the calculated speed is:
    - The same as the current speed, (noted during the Speed Run Calibration) then the calibration is correct at this speed so no action is required.
    - Not the same as the current speed. Calculate a new, corrected Calibration Factor, as follows: e.g. if actual speed equals 8 kts, indicated speed was 7.5 kts and the old Calibration Factor was 1.4 then:
      - new cal factor = actual speed x old factor / indicated speed
      - new cal factor =  $8 \times 1.4 / 7.5$
      - new cal factor =  $11.2 / 7.5$
      - new cal factor = 1.49

## Adding a Calibration Point

Calibration Points can be manually added to the Calibration Table. The amount of Calibration Points that can be stored is determined by the type of speed transducer and method of connection.

From the Transducer found menu: **Menu > Set-up > Transducer set-up > Continue** :



1. Select the device that the transducer(s) you are calibrating are connected to.  
A list of available transducer data is displayed.
2. \* Select **Speed**.

**Important:** \* Step only applicable to iTC-5.

3. Select **Speed Calibration**.
4. Select **Advanced**.
5. Select **Adjust Calibration**.
6. Select **Start**.  
The current Calibration Table is displayed.
7. Select the relevant Calibration Point from the table.
8. Select **Options**.
9. Select **Add cal point**.
10. Use the **Up** and **Down** buttons to adjust the displayed Log Speed to match SOG, if available or to match your estimated actual speed.
11. Select **Add**.
12. Select **Ok**.
13. Repeat steps 7 to 11 for each Calibration Point you want to add.

*The more Calibration Points the higher the accuracy of Log Speed.*

**Note:** If the text appears red then the new reading deviates too far from the stored reading. You will need to add a Calibration Point closer to the stored reading a try again.

### Editing a Calibration Point

Existing Calibration Points can be manually edited.

From the Advanced Menu:

1. Select **Adjust cal table**.
2. Select **Start**.
3. Highlight the relevant Calibration Point from the table.
4. Select **Options**.
5. Select **Edit cal point**.  
The Calibration Point Adjustment page is displayed.
6. Use the **Up** and **Down** buttons to adjust the Calibration Factor for the selected speed to match your new Calibration Factor.
7. Select **Done** to return to the Calibration Table.
8. Repeat steps 4 to 7 for all Calibration Points that require adjustment.
9. Select **Finish** when all of the required Calibration Points have been adjusted.

### Deleting a Calibration Point

Calibration Points can be deleted from the Calibration Table.

From the Adjust cal table menu:

1. Select **Start**.
2. Highlight the Calibration Point you want to delete.
3. Select **Options**.

4. Select **Yes** to delete.  
The Calibration Point is deleted from the Calibration Table.

### Resetting the Calibration Table

The Calibration Table can be reset to factory default values by following the steps below:

From the Advanced Menu:

1. Select **Reset to defaults**.
2. Select **Yes**.
3. Select **Ok**.

The Calibration Table is reset to factory default values.

### Entering a new Calibration Table

A new Calibration Table can be added manually. The new Calibration Table replaces the existing table which is deleted. This is useful when you have been provided a specific calibration table for your hull type.

**Note:** You will need to work out your Calibration Factors for each Calibration Point before you can create the new Calibration Table.

From the Advanced Menu:

1. Select **Enter new cal table**.
2. Select **Start**.

All existing Calibration Points are deleted and you will be prompted to enter new Calibration Points.

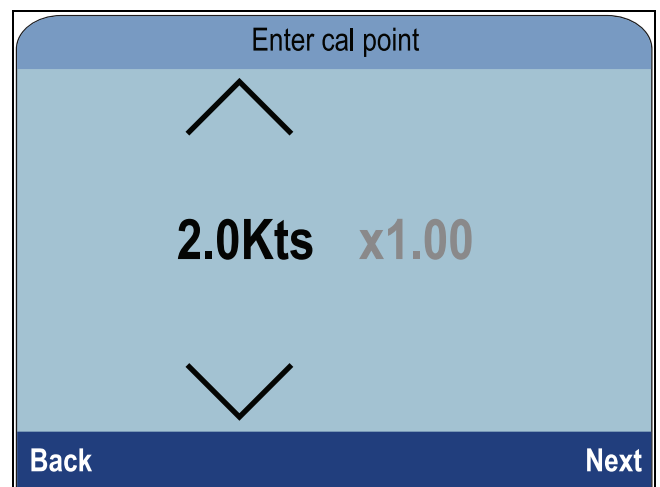

3. Use the **Up** and **Down** buttons to select the desired speed that you want to add a Calibration Point for.
4. Select **Next**.
5. Use the **Up** and **Down** buttons to adjust the Calibration Factor to the correct value.
6. Select **Done**.
7. Select **Add** to add the next Calibration Point.
8. Repeat steps 3 to 7 for all Calibration Points you want to add.
9. Select **Finish** when all Calibration Points have been added.
10. Select **OK**.

## Calibrating Water Temperature

The Water Temperature reading can be calibrated as follows:

You will need a suitable thermometer to measure the Water Temperature.

From a favorite page:

1. Select **Menu**.
2. Select **Set-up**.
3. Select **Transducers Set-up**.
4. Select **Continue**.

The instrument display will search for and display a list of connected devices. (i.e. iTC-5, DST or transducer pod)

5. Select the device that the transducer(s) you are calibrating are connected to.

A list of available transducer data is displayed,

6. \* Select **Speed**.

**Important:** \* Step only applicable to iTC-5.

7. Select **Current Temperature** option.
8. Use a suitable thermometer to measure the actual water temperature.
9. Use the **Up** and **Down** buttons to match the displayed Water Temperature to the actual Water Temperature measured by the thermometer.
10. Select **Save** to save the setting.

## 7.4 Wind calibration

### Calibrating wind

- You will need to be underway, with sufficient space to turn in a large slow circle unhindered.
- Conditions should be calm (i.e. a slight sea) and a steady breeze. Try to ensure the vessel is not rolling or pitching too much.

From a favorite page:

1. Select **Menu**.
2. Select **Set-up**.
3. Select **Transducers Set-up**.
4. Select **Continue**.

The instrument display will search for and display a list of connected devices. (i.e. iTC-5, DST or transducer pod)

5. Select the device that the transducer(s) you are calibrating are connected to.

A list of available transducer data is displayed,

6. \* Select **Wind**.

**Important:** \* Step only applicable to iTC-5.

7. Select **Calibrate Wind Xdcr**.
8. Keep the vessel speed below 2 kts and observing the screen, start to turn the vessel in a circle, then select **Start**.
9. Continue turning the vessel in circles until **Complete** is displayed on-screen.

If your rate of turn is too fast during calibration, a **Slow Down** message is displayed. If this happens, reduce your rate of turn this can be achieved by slowing down and / or steering in a wider circle.

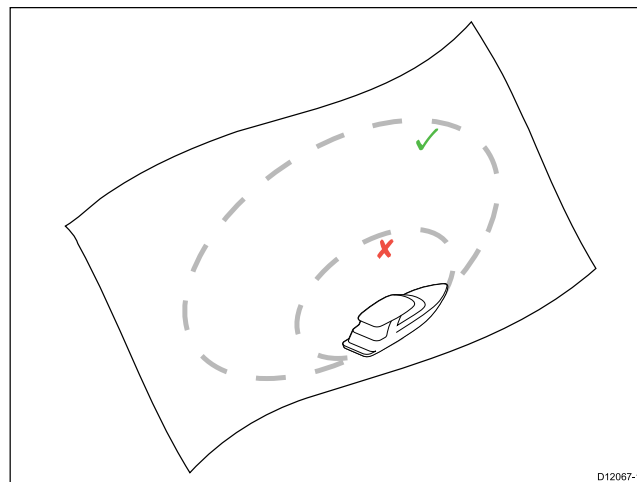

10. Select **Continue**.
11. If required use the **UP** and **DOWN** buttons to manually adjust the vane offset.
12. Press **SELECT** to complete the calibration process and save the settings.

If required you can manually adjust each part of the calibration steps by selecting the relevant options from the **Wind** menu.

### Aligning the wind transducer

- You will need to be underway, with sufficient space to turn in a large slow circle unhindered.



- Conditions should be calm (i.e. a slight sea) and a steady breeze. Try to ensure the vessel is not rolling or pitching too much.

From the list of transducers found:

1. Select the device that the transducer(s) you are calibrating are connected to.  
A list of available transducer data is displayed,
2. \* Select **Wind**.

**Important:** \* Step only applicable to iTC-5.

3. Select **Align Wind Xdcr**.
4. Now steer your vessel directly into the wind and select **Continue**.

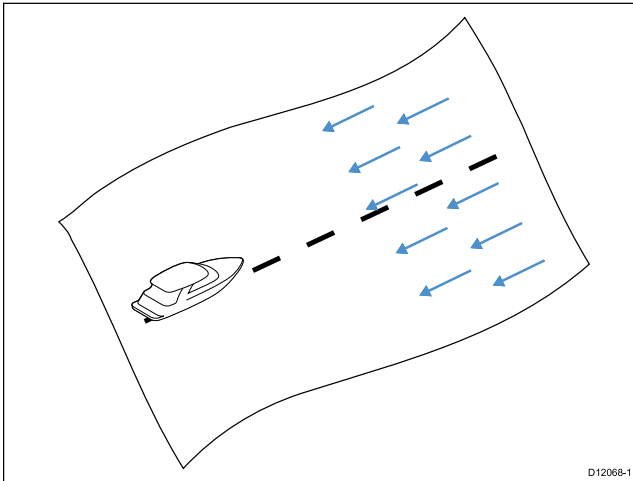

## Adjusting the wind transducer

You can manually adjust the offset.

- You will need to be underway, with sufficient space to turn in a large slow circle unhindered.
- Conditions should be calm (i.e. a slight sea) and a steady breeze. Try to ensure the vessel is not rolling or pitching too much.

From the list of transducers found:

1. Steer your vessel directly into the wind

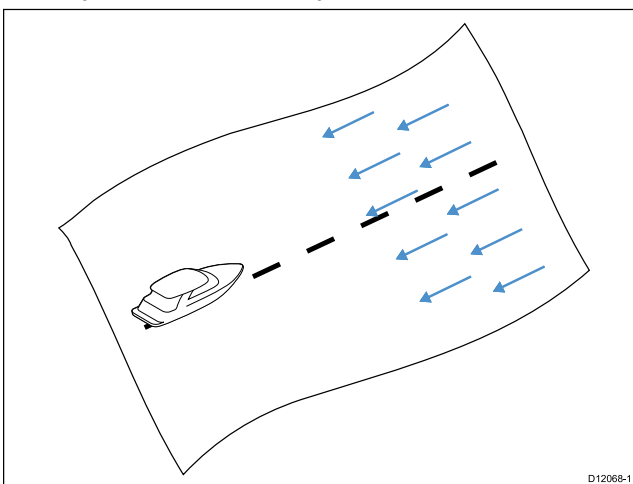

With your vessel sailing directly into the wind the Apparent Wind Angle (AWA) should be 0 degrees.

2. Select the device that the transducer(s) you are calibrating are connected to.  
A list of available transducer data is displayed,

3. \* Select **Wind**.

**Important:** \* Step only applicable to iTC-5.

4. Select **Wind Xdcr Adjust**.

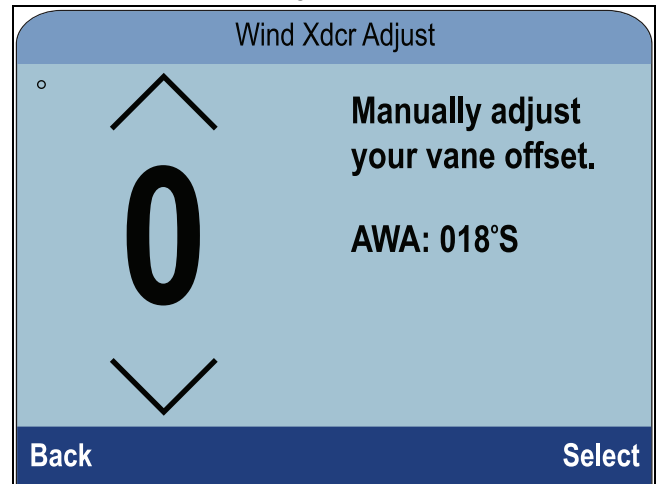

5. Use the **Up** and **Down** buttons to adjust the offset value so that the reported AWA is 0 degrees.

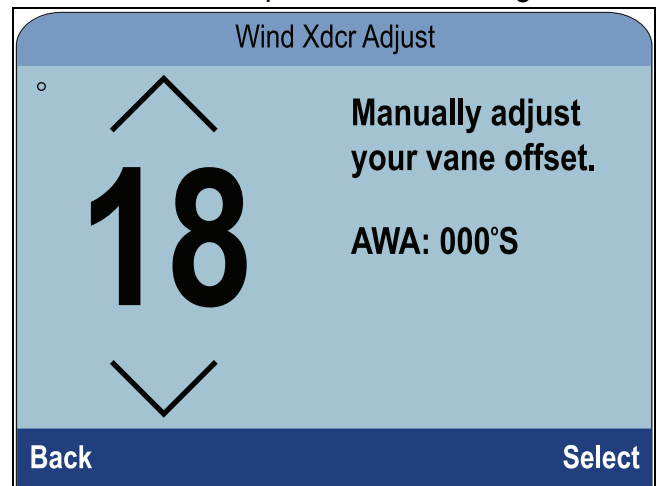

6. Select **Select**.

## Adjusting apparent wind speed

To apply a Calibration Factor to the Apparent Wind Speed (AWS) reading follow the steps below.

- To apply an offset to your AWS readings an accurate reference for AWS must be used to compare the instrument's AWS reading against.
- Conditions should be calm (i.e. a slight sea) and a steady breeze. Try to ensure the vessel is not rolling or pitching too much.

From the list of transducers found:

1. Select the device that the transducer(s) you are calibrating are connected to.  
A list of available transducer data is displayed,
2. \* Select **Wind**.

**Important:** \* Step only applicable to iTC-5.

3. Select **App Wind Speed**.  
The AWS Calibration Factor page is displayed.

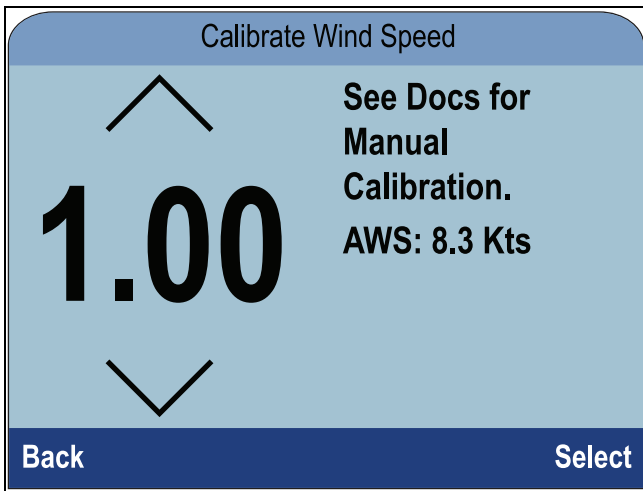

- Use the **Up** and **Down** buttons to adjust the Calibration Factor until the AWS reading matches your referenced source of AWS.

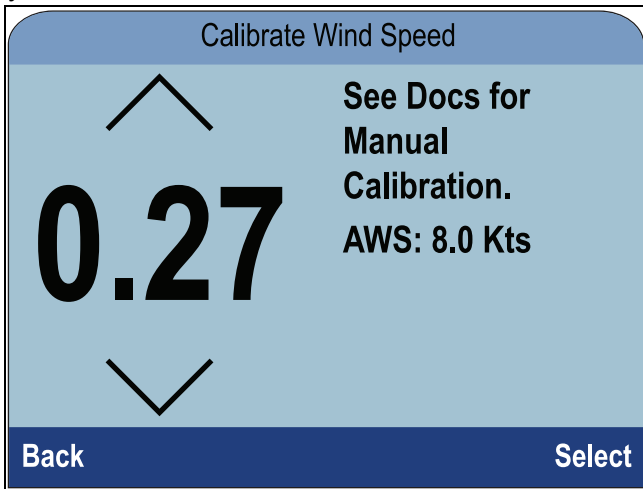

The Calibration Factor default is 1.00 the Calibration Factor can be adjusted from 0.25 to 2.00.

- Select **Select** to save the Calibration Factor.

## 7.5 Rudder reference calibration

You can calibrate a rudder reference transducer that is connected to an iTC-5.

The rudder reference transducer must be connected to the rudder reference connection of the iTC-5 . Rudder reference transducers connected to an autopilot must be calibrated using the pilot controller.

### Centering the Rudder

Centering the Rudder requires a method of knowing the Rudder's actual position.

From a favorite page:

- Select **Menu**.
- Select **Set-up**.
- Select **Transducers Set-up**.
- Select **Continue**.

The instrument display will search for and display a list of connected devices. (i.e. iTC-5, DST or transducer pod)

- Select **iTC-5**.  
A list of available transducer data is displayed,
- Select **Rudder**.
- Select **Centre Rudder**.

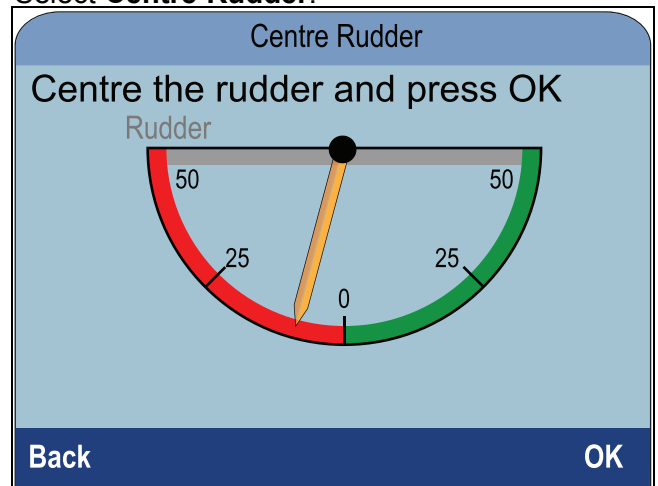

- Turn the steering until the Rudder is centred.

*The Rudder Reference has indicators on its base and on the rudder arm, ensure these marks are lined up.*

- With the Rudder centered, select **Ok**.  
The pointer is zeroed on the display.

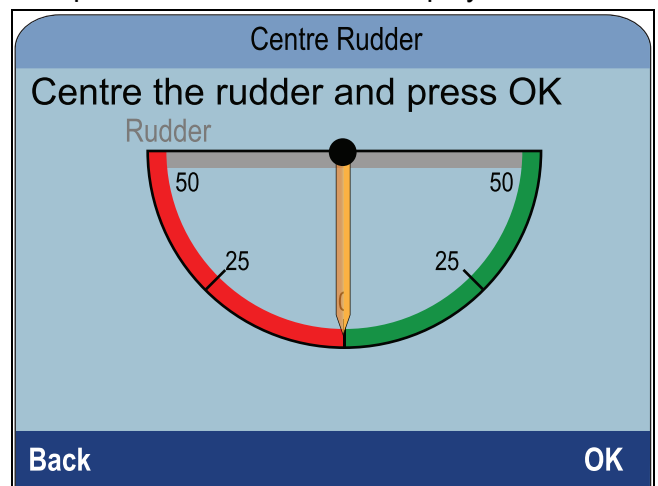

10. Select **Back** to return to the Rudder Calibration Menu.

## Adjusting the Rudder Angle

You can manually adjust the Rudder Angle.

Manual adjustment of the Rudder Angle requires a method of knowing the Rudder's actual position.

From the transducers found page:

1. Ensure that the rudder is centered centred
2. Select **iTC-5**.  
A list of available transducer data is displayed.
3. Select **Rudder**.
4. Select **Adjust Rudder Angle**.

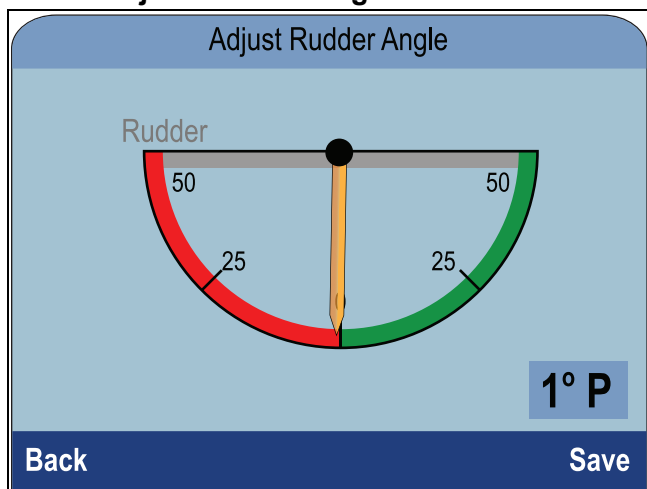

5. Use the **Up** and **Down** buttons to adjust the pointer so that the pointer and the reported Rudder Angles are both zero.
6. Select **Save**.

## Inverting the Rudder

If the display's Rudder Pointer moves in the opposite direction (i.e. when you turn the Rudder starboard the pointer moves port) this can be corrected by inverting the Rudder.

From the transducers found page:

1. Ensure that the rudder is centred.
2. Select **iTC-5**.  
A list of available transducer data is displayed.
3. Select **Rudder**.
4. Select **Invert Rudder Angle**.
5. If the pointer is pointed in the opposite direction than that expected, select **Invert**.

## 7.6 Compass calibration

You can calibrate a Fluxgate Compass that is connected to an iTC-5.

The compass must be connected to the compass connection of the iTC-5. Compasses connected to an autopilot must be calibrated using a Pilot Controller.

### Swinging the Compass

You will need to turn your vessel in slow circles while the system automatically makes adjustments to account for Compass Deviation. Each 360-degree circle should take no less than two minutes, and you should complete at least two circles.

It is recommended that a second instrument display or MFD is used to display heading data, whilst performing the Compass Swing.

From a favorite page:

1. Select **Menu**.
2. Select **Set-up**.
3. Select **Transducers Set-up**.
4. Select **Continue**.  
The instrument display will search for and display a list of connected devices. (i.e. iTC-5, DST or transducer pod)
5. Select **iTC-5**.  
A list of available transducer data is displayed,
6. Select **Compass**.
7. Select **Swing Compass**.
8. Start moving vessel in slow even circles, then press **Start**.
9. Keep vessel speed to below 2 knots. Watch the display to ensure your turn rate is not too fast. If the message 'Slow Down — turn rate too fast' is displayed reduce your rate of turn, this can be achieved by slowing down and / or steering in a wider circle.

*If the 'Slow Down — turn rate too fast' message is displayed the current circle will have to be repeated.*

When the Compass has been calibrated, a message will be displayed showing the detected Compass Deviation.

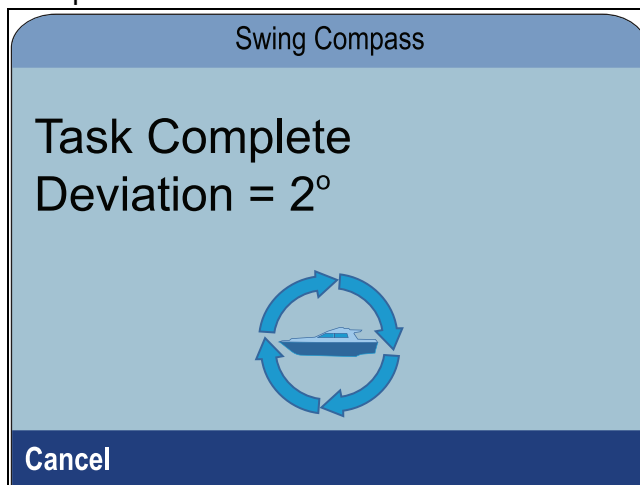

10. If the deviation is greater than 15 degrees you will need to relocate the Compass further away from

metal items or items that may cause interference, then repeat the calibration process. If you still find a deviation of more than 15 degrees, contact your Raymarine dealer for advice. If the deviation is within acceptable limits, press **Cancel**.

## Setting the Compass Offset

You can manually apply an offset to the Compass heading by following the steps below.

To apply an offset you require a source of heading such as the ship's compass.

From the transducers found page:

1. Ensure that the Rudder is centred
2. Select **iTC-5**.  
A list of available transducer data is displayed.
3. Select **Compass**.
4. Select **Compass Offset**.
5. Steer your vessel on a steady course.
6. Use the **Up** and **Down** buttons to adjust the Compass Offset until the displayed heading matches the heading of the ship's compass.
7. Select **Save**.

# Chapter 8: Favorite Pages

## Chapter contents

- [8.1 Favorite pages on page 54](#)
- [8.2 Customizing pages on page 54](#)

## 8.1 Favorite pages

The unit displays data on Favorite pages. The Favorite pages displayed are dependent on the Boat Type selected during the Startup Wizard.

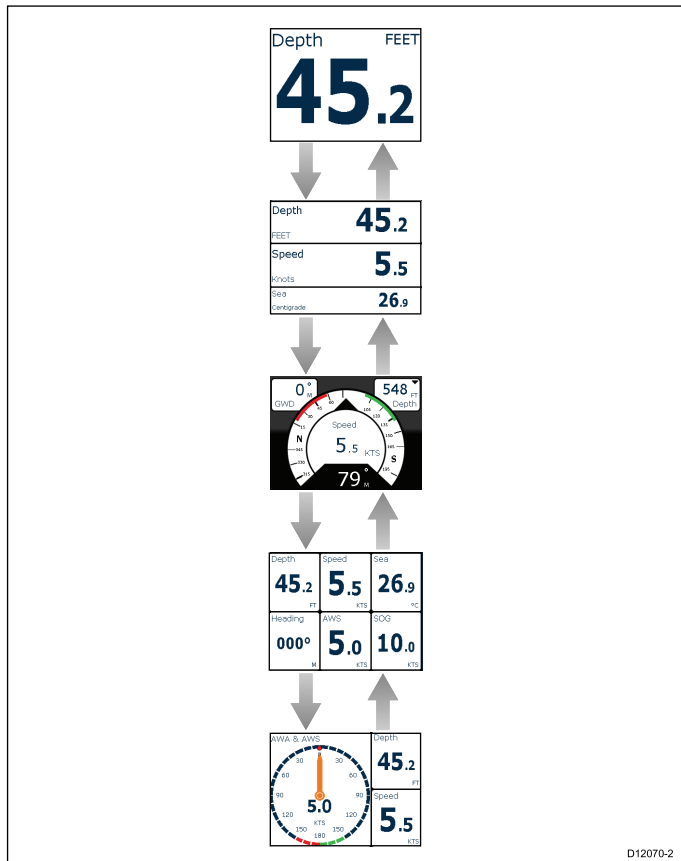

### Selecting pages

1. Use the **Up** and **Down** buttons to cycle through the available pages.

Alternatively you can use the Rollover feature: (**Menu > Favorite Pages > Rollover**) to automatically cycle through the available pages.

## 8.2 Customizing pages

Favorite pages can be customized from the **Favorites page** menu. You can:

- Edit an existing page.
- Add new pages.
- Delete pages.
- Change page order.
- Set pages to Rollover

### Editing an existing page

The layout and data displayed on each page can be changed.

With the page that you want to edit displayed onscreen:

1. Select **Menu**.
2. Select **Quick Options**.
3. Select **Edit Page**.
4. Select the page that you want to edit.

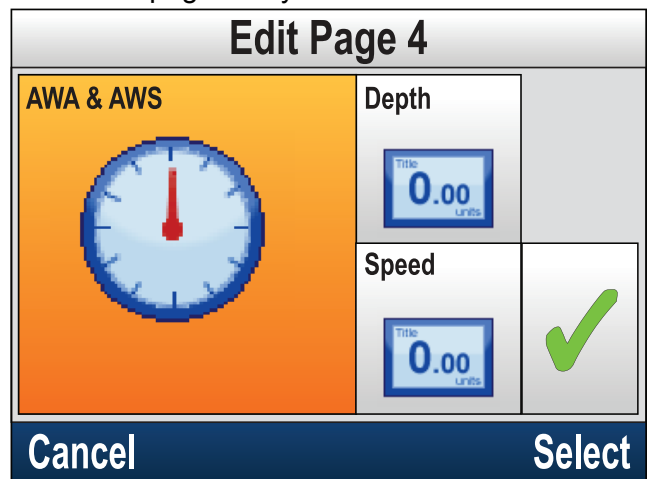

5. Use the **Up** and **Down** buttons to highlight the cell that you want to change.
6. Press the **Menu** button to choose a new data item.
7. Select a data item category.
8. Select the data item/layout from the category list.

*If a data item cannot be displayed in the selected cell it will be grayed out.*

9. Follow steps 5 to 8 for the remaining cells that you want to change.
10. When finished highlight the onscreen tick and select **Save**.

The **Edit page** menu is also available from the **Favorites Pages** menu: (**Menu > Favorite Pages > Edit Page**).

### Adding a page

You can add new custom Favorite pages.

The maximum number of Favorite pages is 10.

From the Main menu:

1. Select **Favorite Pages**.
2. Select **New Page** from the menu.

If you already have 10 Favorite pages, you cannot add another page without first deleting

- one of the existing pages. Otherwise you will be taken to a page layout option screen.
3. Select the required layout.
  4. Select a cell.
  5. Browse the Data Categories list and select the Data item that you want to display in the selected cell.
  6. Complete steps 2 and 3 for all remaining cells.
  7. When finished highlight the onscreen tick and select **Save**.
2. Select **Quick Options**.
  3. Select the relevant Reset options.

The new page is added to the bottom of the current set of Favorite pages.

## Deleting a page

To delete a page follow the steps below.

The minimum number of Favorite pages is one.

From the Favorite Pages menu: (**Menu > Favorite Pages**).

1. Select **Delete Page**.  
If you have two or more pages you will be able to delete a page.
2. Select a the page that you want to delete.
3. Select **Yes**.

The page is now deleted.

## Changing the page order

From the Favorite Pages menu: (**Menu > Favorite Pages**).

1. Select **Page order**.
2. Select the page you wish to move.

*Page numbers are shown momentarily when you manually cycle through Favorite pages.*

3. Use the **Up** and **Down** buttons to select the new location for the page.
4. Select **Save**.

## Setting page Rollover

Using the Rollover feature enables the Favorite pages to cycle automatically.

From the **Favorite Pages** menu:

1. select **Rollover**.
2. Select a Time interval, or .

*The Time intervals available are: 2 Secs, 5 Secs, and 10 Secs.*

3. Select **Off** to switch Rollover off.

## Resetting accumulative data

Minimum, Average, Maximum and distance data accumulates over time and can be reset.

The data item you want to reset must be displayed onscreen either as part of a Favorite page or as a Data (Quick view) page.

1. Press the **Menu** button.





## Chapter 9: Data (Quick View)

### Chapter contents

- [9.1 Data items on page 58](#)
- [9.2 Viewing Data \(Quick View\) on page 60](#)
- [9.3 Adding a Quick View as a Favorite page on page 61](#)

## 9.1 Data items

The table below shows a list of possible data items available to display on **Favorite Pages** and using the **Data (Quick View)** menu.

**Note:** The data described in the table below is dependent on the devices that are connected to your system.

Data Category	Favorite Page (Data Items)	Quick View (Data Items)
<b>AIS</b>	<ul style="list-style-type: none"> <li>• AIS</li> </ul>	<ul style="list-style-type: none"> <li>• AIS</li> </ul>
<b>Battery</b> <sup>(1)</sup>	<ul style="list-style-type: none"> <li>• Battery Current</li> <li>• Battery Temperature</li> <li>• Battery Volts</li> </ul>	<ul style="list-style-type: none"> <li>• Battery Current</li> <li>• Battery Temperature</li> <li>• Battery Volts</li> </ul>
<b>Boat</b>	<ul style="list-style-type: none"> <li>• Rate of Turn</li> <li>• Tilt</li> <li>• Trim Tabs</li> <li>• Gray Water Tank</li> <li>• Black Water Tank</li> <li>• Fresh Water Tank</li> </ul>	<ul style="list-style-type: none"> <li>• Rate of Turn</li> <li>• Tilt</li> </ul>
<b>Depth</b>	<ul style="list-style-type: none"> <li>• Depth</li> <li>• Max Depth</li> <li>• Min Depth</li> <li>• Depth History</li> </ul>	<ul style="list-style-type: none"> <li>• Depth</li> <li>• Depth History</li> <li>• Max Depth</li> <li>• Min Depth</li> </ul>
<b>Distance</b>	<ul style="list-style-type: none"> <li>• Log</li> <li>• Trip</li> </ul>	<ul style="list-style-type: none"> <li>• Log</li> <li>• Trip</li> </ul>
<b>Engine</b> <sup>(1)</sup>	<ul style="list-style-type: none"> <li>• Engine Hours</li> <li>• Trim Position</li> <li>• RPM</li> <li>• Oil Pressure</li> <li>• Oil Temperature</li> <li>• Coolant Pressure</li> <li>• Coolant Temperature</li> <li>• Boost Pressure</li> <li>• Load</li> <li>• Alternator Potential</li> <li>• Transmission Oil Pressure</li> <li>• Transmission Oil Temperature</li> <li>• Transmission</li> <li>• 2 Engine Overview</li> </ul>	<ul style="list-style-type: none"> <li>• Boost Pressure</li> <li>• Coolant Pressure</li> <li>• Coolant Temperature</li> <li>• Engine Hours</li> <li>• RPM</li> <li>• Oil Pressure</li> <li>• Oil Temperature</li> <li>• Trim Position</li> <li>• Load</li> <li>• Alternator Potential</li> <li>• Transmission Oil Pressure</li> <li>• Transmission Oil Temperature</li> <li>• Transmission</li> <li>• 2 Engine Overview</li> </ul>

Data Category	Favorite Page (Data Items)	Quick View (Data Items)
	<ul style="list-style-type: none"> <li>• 1 Engine Overview</li> </ul>	<ul style="list-style-type: none"> <li>• 1 Engine Overview</li> </ul>
<b>Environment</b>	<ul style="list-style-type: none"> <li>• Sea Temperature</li> <li>• Max Sea Temperature</li> <li>• Min Sea Temperature</li> <li>• Sea Temperature History</li> <li>• Barometric Pressure</li> <li>• Barometric Pressure History</li> <li>• Air Temperature</li> <li>• Max Air Temperature</li> <li>• Min Air Temperature</li> <li>• Air Temperature History</li> <li>• Sunset / Sunrise</li> <li>• Set</li> <li>• Drift</li> <li>• Wind Chill Apparent</li> <li>• Wind Chill True</li> <li>• Dew Point</li> <li>• Humidity</li> </ul>	<ul style="list-style-type: none"> <li>• Air Temperature</li> <li>• Air Temperature History</li> <li>• Barometric Pressure</li> <li>• Barometric Pressure History</li> <li>• Dew Point</li> <li>• Drift</li> <li>• Drift History</li> <li>• Humidity</li> <li>• Min Air Temperature</li> <li>• Max Air Temperature</li> <li>• Sea Temperature</li> <li>• Min Sea Temperature</li> <li>• Max Sea Temperature</li> <li>• Sea Temperature History</li> <li>• Set</li> <li>• Set History</li> <li>• Set &amp; Drift Pair</li> <li>• Sunset / Sunrise</li> <li>• Wind Chill Apparent</li> <li>• Wind Chill True</li> </ul>
<b>Fuel</b> <sup>(1)</sup> Fuel management is dependent on engine data that is available on <b>SeaTalk<sup>ng</sup></b> ®.	<ul style="list-style-type: none"> <li>• Distance To Empty</li> <li>• Fuel Flow Rate</li> <li>• Fuel Flow Rate Total</li> <li>• Fuel Flow – Average</li> <li>• Fuel Economy</li> <li>• Total Fuel</li> <li>• Est. Fuel Remaining</li> <li>• Fuel Level</li> <li>• Fuel Pressure</li> </ul>	<ul style="list-style-type: none"> <li>• Distance To Empty</li> <li>• Fuel Flow Rate</li> <li>• Fuel Flow Rate Total</li> <li>• Fuel Economy</li> <li>• Fuel Flow – Average</li> <li>• Fuel Level</li> <li>• Total Fuel</li> <li>• Est. Fuel Remaining</li> <li>• Fuel Pressure</li> </ul>

Data Category	Favorite Page (Data Items)	Quick View (Data Items)
<b>GPS</b>	<ul style="list-style-type: none"> <li>• SOG</li> <li>• SOG History</li> <li>• Max. SOG</li> <li>• Avg. SOG</li> <li>• COG</li> <li>• COG History</li> <li>• COG and SOG</li> <li>• Latitude</li> <li>• LAT &amp; LON</li> <li>• Longitude</li> <li>• SATS</li> <li>• HDOP</li> <li>• SATS + HDOP</li> </ul>	<ul style="list-style-type: none"> <li>• COG</li> <li>• COG History</li> <li>• COG and SOG</li> <li>• HDOP</li> <li>• Latitude</li> <li>• LAT &amp; LON</li> <li>• Longitude</li> <li>• SATS</li> <li>• SATS + HDOP</li> <li>• SOG</li> <li>• SOG History</li> <li>• Max. SOG</li> <li>• Avg. SOG</li> </ul>
<b>Heading</b>	<ul style="list-style-type: none"> <li>• Heading</li> <li>• Heading &amp; speed</li> <li>• Heading History</li> <li>• Locked Heading</li> <li>• Error &amp; Locked Heading</li> <li>• Tack Heading</li> <li>• Heading (Multi-gauge)</li> </ul>	<ul style="list-style-type: none"> <li>• Heading</li> <li>• Heading &amp; speed</li> <li>• Heading History</li> <li>• Locked Heading</li> <li>• Error &amp; Locked Heading</li> <li>• Tack Heading</li> <li>• Heading (Multi-gauge)</li> </ul>

Data Category	Favorite Page (Data Items)	Quick View (Data Items)
<b>Navigation</b>	<ul style="list-style-type: none"> <li>• Active Waypoint Name</li> <li>• Waypoint ID</li> <li>• Course Made Good</li> <li>• CMG &amp; DMG</li> <li>• CMG &amp; VMG</li> <li>• Distance Made Good</li> <li>• BTW</li> <li>• BTW &amp; DTW</li> <li>• DTW</li> <li>• XTE</li> <li>• ETA</li> <li>• TTG</li> <li>• Course to Steer</li> <li>• CTS &amp; XTE</li> <li>• Rolling Road</li> <li>• Turn</li> <li>• Turn &amp; DTW</li> </ul>	<ul style="list-style-type: none"> <li>• Active Waypoint Name</li> <li>• Waypoint ID</li> <li>• Course Made Good</li> <li>• CMG History</li> <li>• BTW</li> <li>• DTW</li> <li>• BTW &amp; DTW</li> <li>• Distance Made Good</li> <li>• CMG &amp; DMG</li> <li>• CMG &amp; VMG</li> <li>• Course to Steer</li> <li>• CTS &amp; XTE</li> <li>• ETA</li> <li>• TTG</li> <li>• XTE</li> <li>• XTE History</li> <li>• Rolling Road</li> <li>• Turn</li> <li>• Turn &amp; DTW</li> </ul>
<b>Pilot</b>	<ul style="list-style-type: none"> <li>• Pilot Heading</li> <li>• Pilot Heading &amp; Speed Pair</li> <li>• Pilot Status</li> <li>• Rudder Angle</li> </ul>	<ul style="list-style-type: none"> <li>• Pilot Heading</li> <li>• Pilot Heading &amp; Speed Pair</li> <li>• Pilot Status</li> <li>• Rudder Angle</li> </ul>
<b>Speed</b>	<ul style="list-style-type: none"> <li>• Speed</li> <li>• Trolling Speed</li> <li>• Max Speed</li> <li>• Average Speed</li> <li>• VMG Windward</li> <li>• VMG WPT</li> <li>• Boat Speed &amp; SOG</li> <li>• Speed History</li> </ul>	<ul style="list-style-type: none"> <li>• Average Speed</li> <li>• Boat Speed &amp; SOG</li> <li>• Max Speed</li> <li>• Speed</li> <li>• Speed History</li> <li>• Trolling Speed</li> <li>• VMG Windward</li> <li>• VMG Windward History</li> <li>• VMG WPT</li> <li>• VMG WPT History</li> </ul>

Data Category	Favorite Page (Data Items)	Quick View (Data Items)
<b>Time</b>	<ul style="list-style-type: none"> <li>• Local Time</li> <li>• Time &amp; Date</li> <li>• Clock</li> <li>• Race Timer</li> </ul>	<ul style="list-style-type: none"> <li>• Clock</li> <li>• Local Time</li> <li>• Time &amp; Date</li> <li>• Race Timer</li> </ul>
<b>Wind</b>	<ul style="list-style-type: none"> <li>• AWS</li> <li>• AWS History</li> <li>• AWS Min</li> <li>• AWS Max</li> <li>• AWA</li> <li>• AWA &amp; AWS</li> <li>• AWA (CH) &amp; AWS</li> <li>• AWA &amp; VMG</li> <li>• AWA History</li> <li>• AWA Min</li> <li>• AWA Max</li> <li>• TWS</li> <li>• TWS History</li> <li>• TWS Min</li> <li>• TWS Max</li> <li>• TWA</li> <li>• TWA &amp; TWS</li> <li>• TWA (CH) &amp; TWS</li> <li>• TWA &amp; VMG</li> <li>• TWA History</li> <li>• TWA Min</li> <li>• TWA Max</li> <li>• GWD</li> <li>• GWD &amp; Beaufort</li> <li>• GWD History</li> <li>• Cardinal</li> <li>• Beaufort</li> <li>• TWD</li> <li>• TWD History</li> </ul>	<ul style="list-style-type: none"> <li>• AWA</li> <li>• AWA History</li> <li>• AWA &amp; AWS</li> <li>• AWA (CH) &amp; AWS</li> <li>• AWA &amp; VMG</li> <li>• AWA Max</li> <li>• AWA Min</li> <li>• AWS</li> <li>• AWS History</li> <li>• AWS Max</li> <li>• AWS Min</li> <li>• Beaufort</li> <li>• Cardinal</li> <li>• GWD</li> <li>• GWD History</li> <li>• GWD &amp; Beaufort</li> <li>• TWD</li> <li>• TWD History</li> <li>• TWA</li> <li>• TWA History</li> <li>• TWA &amp; TWS</li> <li>• TWA (CH) &amp; TWS</li> <li>• TWA &amp; VMG</li> <li>• TWA Max</li> <li>• TWA Min</li> <li>• TWS</li> <li>• TWS History</li> <li>• TWS Max</li> <li>• TWS Min</li> </ul>

## 9.2 Viewing Data (Quick View)

You can use the **Data (Quick View)** menu to view data that may not be available on the current Favorite Pages.

1. Select **Data (Quick View)** from the main menu.
2. Select a Data Category.
3. Select the Data item and your preferred graphic type, if available.

The data will be displayed full screen.

**Note:** (1) There may be more than one device configured, Data items will be available for each configured device.

## 9.3 Adding a Quick View as a Favorite page

The Quick View data pages can be added as a Favorite page.

From the **Data (Quick View)** menu:

1. Select the Data item so that it is displayed onscreen.
2. Press the **Menu** button.
3. Select **Quick Options**.
4. Select **Add to Favorites**.



# Chapter 10: AIS

## Chapter contents

- [10.1 AIS Overview on page 64](#)
- [10.2 AIS target symbols on page 65](#)
- [10.3 Setting AIS Range on page 66](#)
- [10.4 Viewing AIS target information on page 66](#)
- [10.5 Enabling and disabling AIS Silent mode on page 67](#)

## 10.1 AIS Overview

When an AIS receiver/transceiver is connected to your system, the AIS feature enables you to receive information broadcast by other AIS equipped vessels, and to view these vessels as targets relative to your boat. The AIS feature on the unit is standalone, settings and alarms cannot be shared with other AIS enabled products on your system.

### How AIS Works

AIS uses digital radio signals to broadcast 'real-time' information between vessels and shore-based stations via dedicated VHF radio frequencies. This information is used to identify and track vessels in the surrounding area and to provide fast, automatic and accurate collision avoidance data.

**Note:** It is not mandatory for vessels to be fitted with operational AIS equipment. Therefore, you should not assume that ALL vessels in your area are displayed.

With an optional AIS unit connected to your system you can:

- Display targets for any other AIS-equipped vessels.
- Display voyage information being broadcast by these targets, such as their position, course, speed and rate-of-turn.
- Display basic or detailed information for each target vessel, including safety-critical target data.
- Set up a safe zone around your vessel.
- View AIS alarm and safety-related messages.

AIS information is displayed on the screen as shown below:

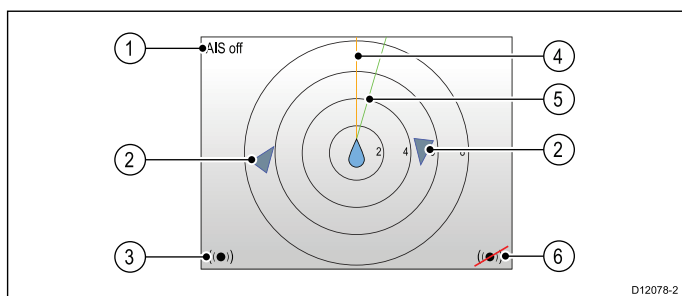

Item	Description
1	AIS text See AIS messages in table below
2	AIS target
3	Dangerous targets alarm on
4	Heading line
5	COG line
6	Dangerous targets alarm off

**Note:** Where unstable or no heading or COG data is available AIS targets and your vessel icon will not be displayed.

## AIS Messages









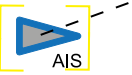

AIS Messages	Description
AIS off	AIS Unit off
(none)	AIS is on and transmitting
Alarm on icon	AIS on, transmitting, alarm is active.
Silent	AIS on & user is silent to other vessels.
Alarm on	AIS on, user is silent to other vessels & alarm is active.
Alarm off icon	AIS on & Alarm off
Data lost	AIS on & data lost.
No fix	AIS on & lost GPS fix.
Insufficient COG/Hdg data	No stable COG or heading data

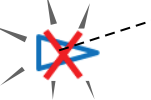



AIS-equipped vessels in the surrounding area are displayed on the page as targets. A maximum of 25 targets can be displayed, where more than 25 targets are in range **Max targets** is displayed onscreen.



## 10.2 AIS target symbols

Your display shows a range of symbols to represent the different types of AIS target.

Target type	Description	Symbol
Transmitting target	Target not activated, dangerous or lost. Target is moving or at anchor.	
Selected target	Target selected with cursor. Can view detailed data.	
Dangerous target	Targets within specified distance (CPA) or time (TCPA). Dangerous target alarm sounds if enabled. Target red and flashes.	
Uncertain target	Calculated CPA / TCPA value uncertain.	
Lost target	When signal of dangerous target not received for 20 seconds. Target in latest predicted position. Alarms sounds if enabled. Target with red cross and flashes.	
Aid To Navigation (AToN) target (Real)	AToN target is ON position.	
Aid To Navigation (AToN) target (Real)	AToN target is OFF position. Target red.	
Aid To Navigation (AToN) target (Real)	AToN target is OFF position & dangerous. Target black and flashes.	
Aid To Navigation (AToN) target (Real)	AToN target is OFF position & lost. Target black with red cross and flashes.	
Aid To Navigation (AToN) target (Virtual)	AToN target is ON position.	
Aid To Navigation (AToN) target (Virtual)	AToN target is OFF position. Target red.	
Aid To Navigation (AToN) target (Virtual)	AToN target is OFF position & dangerous. Target black and flashes.	

Target type	Description	Symbol
Aid To Navigation (AToN) target (Virtual)	AToN target is OFF position & lost. Target black with red cross and flashes.	
Land base station target	Land base station target is ONLINE.	
Yacht	Target vessel type is a yacht.	
Commercial Vessel	Target vessel type is a commercial vessel.	
High speed vessel	Target vessel type is a high speed vessel.	

## 10.3 Setting AIS Range

The distance displayed on the AIS page can be adjusted.

With the AIS page displayed:

1. Press the **Menu** button.
2. Select **Quick options** .
3. Select **AIS Range**.
4. Select the Range you want to display.

## 10.4 Viewing AIS target information

You can view information about AIS targets.

With the AIS page displayed:

1. Press the **Menu** button.
2. Select **Quick Options**.
3. Select **View AIS targets**.
4. Use the **Up** and **Down** buttons to select an AIS target.  
The Name of the vessel will be displayed in the page header.
5. Select **Info** to view detailed target information.  
The information displayed is dependent on the type of target selected.
  - Vessel name
  - MMSI number
  - Vessel type
  - Call sign
  - SOG
6. Use the **Up** and **Down** buttons to scroll through the data.
7. To return to the AIS page, select **Back** .

## 10.5 Enabling and disabling AIS Silent mode

AIS silent mode enables you to disable the transmitting functions of your AIS equipment. This is useful when you do not want to transmit your vessel's AIS data to other AIS receivers, but still wish to receive data from other vessels.

**Note:** Not all AIS equipment supports silent mode. For more information, refer to the documentation that accompanied your AIS unit.

From the AIS page:

1. Press the **Menu** button.
2. Select **Quick options**.
3. Select **AIS Silent mode**.
4. Select **Silent** to stop your AIS position and details being transmitted, or
5. Select **Transmit** to allow your AIS position and details to be received by other AIS equipped vessels.



# Chapter 11: Race timer settings

## Chapter contents

- [11.1 Setting the Race Timer on page 70](#)
- [11.2 Using the Race Timer on page 70](#)

## 11.1 Setting the Race Timer

The Race Timer is used to show the time elapsed since the start of a race. The Race Timer has 3 countdown timers. When a timer count down is complete (reaches zero) then the Race Timer will start to count up.

If the Race Timer has not been added as a Favorite Page then it can be accessed from the **Data (Quick View)** menu: **Menu > Data (Quick View) > Time > Race Timer**.

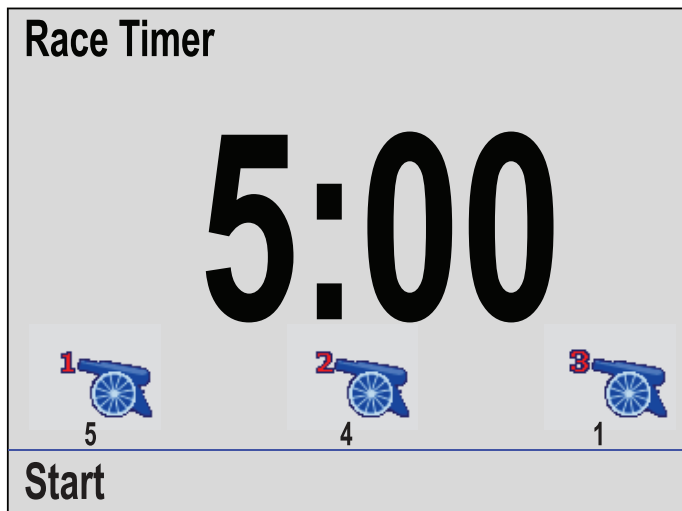

With the Race Timer page displayed:

1. Press the **Menu** button.
2. Select **Quick Options**.
3. Select **Adjust start timers**.
4. Select a start timer
5. Use the **Up** and **Down** buttons to adjust the timer to the required value.
6. Select **Save**.
7. Complete steps 4 to 6 for each start timer you want to adjust.

## 11.2 Using the Race Timer

With the Race Timer page displayed:

1. Select **Start**.
  - The first start timer will begin to count down, audible beeps are sounded as follows:
    - Double beep every minute.
    - Beep Three times at the start of the last 30 seconds.
    - Beep every second for the last 10 seconds.
    - Beep for two seconds when the timer reaches zero
2. You can select **Skip** to skip to the next start timer.

*With the third start timer counting down you can select **Count up** to start the timer counting up from zero.*

3. You can stop the start timer count down by selecting **Stop** from the **Quick Options** menu.
4. When stopped, you can resume the count down by selecting **Resume**.
5. The Race Timer page can be reset by selecting **Reset Timer** from the **Quick Options** menu.

**Note:** You can view other Favorite pages and menus whilst the Race Timer is running.

## Chapter 12: Instrument alarms

### Chapter contents

- [12.1 Alarms on page 72](#)

## 12.1 Alarms

Alarms are used to alert you to a situation or hazard requiring your attention.

Some examples of alarms are:

- Anchor alarm — Used when anchored, this alerts you to a change in depth which could mean that the chain length requires adjusting.
- Depth and speed alarms — These alarms alert you when your depth or speed moves outside of specified limits, for example a minimum depth.
- MOB (Man Overboard) alarm — Received from an MOB system.

When an alarm occurs, a message is displayed and an audible alarm may sound.



You can either:

- Silence the alarm, or
- Silence the alarm and edit the alarm settings.

**Note:** With the exception of the Alarm clock, Speed and Sea temperature; SeaTalk systems will only be able to switch alarms on and off, SeaTalk<sup>ng</sup> systems will also be able to adjust settings.

### Man over Board (MoB) alarm

In the event of a MOB alarm, the instrument provides details to help find the MoB target.



- Brg: Bearing to MoB waypoint.
- Rng: Range to MoB waypoint.
- Elapsed time since start of MoB alarm.

Bearing and Range require GPS data to be available on the network.

## Alarm settings

Most alarms are generated locally using specified thresholds. They are also transmitted to the SeaTalk and SeaTalk<sup>ng</sup> networks for display at other compatible devices.

Category	Alarm		Content
Depth	Shallow	Alarm	<ul style="list-style-type: none"> <li>• On</li> <li>• Off (default)</li> </ul>
		Adjust	<ul style="list-style-type: none"> <li>• 0 — xxx FT</li> <li>• 5 ft (default)</li> </ul>
Depth	Deep	Alarm	<ul style="list-style-type: none"> <li>• On</li> <li>• Off (default)</li> </ul>
		Adjust	<ul style="list-style-type: none"> <li>• 0 — xxx FT</li> <li>• 100 ft (default)</li> </ul>
Depth	Shallow Anchor	Alarm	<ul style="list-style-type: none"> <li>• On</li> <li>• Off (default)</li> </ul>
		Adjust	<ul style="list-style-type: none"> <li>• 0 — xxx FT</li> <li>• 5 ft (default)</li> </ul>
Depth	Deep Anchor	Alarm	<ul style="list-style-type: none"> <li>• On</li> <li>• Off (default)</li> </ul>
		Adjust	<ul style="list-style-type: none"> <li>• 0 — xxx FT</li> <li>• 100 ft (default)</li> </ul>
Speed	Boat Speed High	Alarm	<ul style="list-style-type: none"> <li>• On</li> <li>• Off (default)</li> </ul>
		Adjust	<ul style="list-style-type: none"> <li>• 0 — 100 KTS</li> <li>• 30 kts (default)</li> </ul>
Speed	Boat Speed Low	Alarm	<ul style="list-style-type: none"> <li>• On</li> <li>• Off (default)</li> </ul>
		Adjust	<ul style="list-style-type: none"> <li>• 0 — 100 KTS</li> <li>• 5 kts (default)</li> </ul>



Category	Alarm		Content
Temperature	Sea Temp. High	Alarm	<ul style="list-style-type: none"> <li>On</li> <li>Off (default)</li> </ul>
		Adjust	<ul style="list-style-type: none"> <li>0 — 50°C</li> <li>10°C (default)</li> </ul>
Temperature	Sea Temp. Low	Alarm	<ul style="list-style-type: none"> <li>On</li> <li>Off (default)</li> </ul>
		Adjust	<ul style="list-style-type: none"> <li>0 — 50°C</li> <li>1°C (default)</li> </ul>
Wind	AWS High Apparent Wind Speed high	Alarm	<ul style="list-style-type: none"> <li>On</li> <li>Off (default)</li> </ul>
		Adjust	<ul style="list-style-type: none"> <li>0 — 200 KTS</li> <li>25 kts (default)</li> </ul>
Wind	AWS Low Apparent Wind Speed low	Alarm	<ul style="list-style-type: none"> <li>On</li> <li>Off (default)</li> </ul>
		Adjust	<ul style="list-style-type: none"> <li>0 — 200 KTS</li> <li>10 kts (default)</li> </ul>
Wind	AWA High Apparent Wind Angle high	Alarm	<ul style="list-style-type: none"> <li>On</li> <li>Off (default)</li> </ul>
		Adjust	<ul style="list-style-type: none"> <li>0 — 180°</li> <li>25° (default)</li> </ul>
Wind	AWA Low Apparent Wind Angle low	Alarm	<ul style="list-style-type: none"> <li>On</li> <li>Off (default)</li> </ul>
		Adjust	<ul style="list-style-type: none"> <li>0 — 180°</li> <li>10° (default)</li> </ul>
Wind	TWS High True Wind Speed high	Alarm	<ul style="list-style-type: none"> <li>On</li> <li>Off (default)</li> </ul>
		Adjust	<ul style="list-style-type: none"> <li>0 — 200 KTS</li> <li>10 kts (default)</li> </ul>
Wind	TWS Low True Wind Speed low	Alarm	<ul style="list-style-type: none"> <li>On</li> <li>Off (default)</li> </ul>
		Adjust	<ul style="list-style-type: none"> <li>0 — 200 KTS</li> <li>10 kts (default)</li> </ul>
Wind	TWA High True Wind Angle high	Alarm	<ul style="list-style-type: none"> <li>On</li> <li>Off (default)</li> </ul>
		Adjust	<ul style="list-style-type: none"> <li>0 — 180°</li> <li>25° (default)</li> </ul>
Wind	TWA Low True Wind Angle low	Alarm	<ul style="list-style-type: none"> <li>On</li> <li>Off (default)</li> </ul>
		Adjust	<ul style="list-style-type: none"> <li>0 — 180°</li> <li>10° (default)</li> </ul>
Other	Alarm Clock	Alarm	<ul style="list-style-type: none"> <li>On</li> <li>Off (default)</li> </ul>
		Time	<ul style="list-style-type: none"> <li>12:00 am — 12:00 pm</li> <li>00.00 – 23:59 24 hr</li> </ul>
		Format	<ul style="list-style-type: none"> <li>24 hour</li> <li>am / pm</li> </ul>
Other	Off Course	Alarm	<ul style="list-style-type: none"> <li>On</li> <li>Off (default)</li> </ul>
		Adjust	<ul style="list-style-type: none"> <li>0 — 180°</li> <li>5° (default)</li> </ul>
Other	MOB Man Overboard	Alarm	<ul style="list-style-type: none"> <li>On (default)</li> <li>Off</li> </ul>
Other	Battery Low	Alarm	<ul style="list-style-type: none"> <li>On</li> <li>Off (default)</li> </ul>
		Adjust	<ul style="list-style-type: none"> <li>6 – 60 V</li> <li>10 V (default)</li> </ul>

Category	Alarm		Content
Other	AIS Alarm	<b>Safety messages</b>	<ul style="list-style-type: none"> <li>• On</li> <li>• Off (default)</li> </ul>
		<b>Dangerous target</b>	<ul style="list-style-type: none"> <li>• On</li> <li>• Off (default)</li> </ul>
		<b>Safe zone</b>	<ul style="list-style-type: none"> <li>• (0.1 , 0.2, 0.5, 1.0, 2.0) nm</li> <li>• (0.1 , 0.2, 0.5, 1.0, 2.0) sm</li> <li>• (0.2, 0.5, 1.0, 2.0, 5.0) km</li> </ul>
		<b>Time to safe zone</b>	<ul style="list-style-type: none"> <li>• 3 min</li> <li>• 6 min</li> <li>• 12 min</li> <li>• 24 min</li> </ul>

# Chapter 13: Setup menu

## Chapter contents

- [13.1 Setup menu on page 76](#)

## 13.1 Setup menu

The Set-up menu provides settings to configure the unit.

Menu item	Description	Options
<b>Transducer Set-up</b>	Set up and calibrate transducers as detailed in Transducer calibration section above.	List of connected, compatible transducers.
<b>User Preferences</b>	Configure User Preferences.	<ul style="list-style-type: none"> <li>• Time &amp; Date</li> <li>• Units</li> <li>• Language</li> <li>• Boat Type</li> <li>• Boat Details</li> <li>• Variation</li> <li>• Key Beep</li> </ul>
System set up	Configure network groups and data sources.	<ul style="list-style-type: none"> <li>• Network group</li> <li>• Brightness/Color Group</li> <li>• Data Sources</li> <li>• About System Set Up</li> </ul>
Simulator	<p>Enables and disables simulator mode. The simulator produces simulated data to enable you to practice operating the unit.</p> <div style="border: 1px solid black; padding: 5px; margin-top: 10px;"> <p><b>Note:</b> The Simulator will not product simulated data if other product are present on the <b>SeaTalk<sup>ng</sup></b>® network.</p> </div>	<ul style="list-style-type: none"> <li>• On</li> <li>• Off</li> </ul>
Factory reset	Delete user settings and Restore unit to factory default settings.	<ul style="list-style-type: none"> <li>• Yes</li> <li>• No</li> </ul>
Diagnostics	Information About the unit, device connected to the network and a diagnostics Self Test.	<ul style="list-style-type: none"> <li>• About display</li> <li>• About system</li> <li>• Self Test</li> </ul>

## Transducer setup menu

The **Transducer Set-up** menu enables calibration of connected transducers.

Menu item	Description	Options
iTC-5	Enables setup and calibration of transducers connected using an iTC-5.	<ul style="list-style-type: none"> <li>• Depth</li> <li>• Speed</li> <li>• Wind</li> <li>• Rudder reference</li> <li>• Compass</li> </ul>
Depth	Enables setup and calibration of depth transducers and provides the following options: <ul style="list-style-type: none"> <li>• <b>Details</b></li> <li>• <b>Depth offset</b></li> </ul>	<p><b>Details</b> displays can supply information about the installed transducer or interface such as Serial No. and Software version etc.</p> <p><b>Depth offset</b> allows you to set the offset distance so that the displayed depth reading represents the depth to the sea bed from either the keel or the waterline.</p> <ul style="list-style-type: none"> <li>• <b>Depth from:</b> <ul style="list-style-type: none"> <li>– Keel</li> <li>– Transducer</li> <li>– Water line</li> </ul> </li> <li>• <b>Offset:</b> <ul style="list-style-type: none"> <li>– 0 to 99 ft, m</li> </ul> </li> <li>• <b>About depth offset</b></li> </ul>
Speed	Enables setup and calibration of speed transducers and provides the following options: <ul style="list-style-type: none"> <li>• <b>Details</b></li> <li>• <b>Speed calibration</b> speed should be calibrated at each of the speed points shown under speed calibration.</li> <li>• <b>Calibrate water temperature</b></li> </ul>	<p><b>Details</b> displays can supply information about the installed transducer or interface such as Serial No. and Software version etc.</p> <p><b>Speed calibration:</b></p> <ul style="list-style-type: none"> <li>• speed settings are determined by the calibration points stored either in the transducer or the interface unit.</li> </ul> <p><b>Calibrate water temperature:</b></p> <ul style="list-style-type: none"> <li>• xxx °C or °F</li> </ul>
Wind	Enables setup and calibration of wind transducers and provides the following options: <ul style="list-style-type: none"> <li>• <b>Wind detail</b></li> <li>• <b>Calibrate vane</b></li> <li>• <b>App wind speed calibration</b></li> </ul>	<p><b>Details</b> displays information about the installed transducer, Serial No. and Software version etc.</p> <p><b>Calibrate vane-</b> follow the on screen instructions to calibrate the wind vane.</p> <p><b>App wind speed:</b></p> <ul style="list-style-type: none"> <li>• xx kts</li> </ul>
DST800	Enables setup and calibration of DST (Depth, Speed, and Temperature) smart transducers and provides the following options: <ul style="list-style-type: none"> <li>• <b>DST800 details</b></li> <li>• <b>Depth offset</b></li> <li>• <b>Speed calibration</b></li> <li>• <b>Temperature offset</b></li> </ul>	<p><b>DST800 details</b> displays information about the installed transducer, Serial No. and Software version etc.</p> <p><b>Depth offset</b> allows you to set the offset distance so that the displayed depth reading represents the depth to the sea bed from either the keel or the waterline.</p> <ul style="list-style-type: none"> <li>• <b>Depth from:</b> <ul style="list-style-type: none"> <li>– Water line</li> <li>– Keel</li> <li>– Transducer</li> </ul> </li> <li>• <b>Offset:</b> <ul style="list-style-type: none"> <li>– 0 to 99 ft</li> </ul> </li> <li>• <b>About depth offset</b></li> </ul>

Menu item	Description	Options
		<p><b>Speed calibration:</b></p> <ul style="list-style-type: none"> <li>• <b>Add</b> — adds a new speed setting using current SOG reading.</li> <li>• <b>Edit</b> — edits a speed setting in 0.1 kt increments.</li> <li>• <b>Delete</b> — deletes the selected speed setting.</li> <li>• <b>Reset</b> — resets speed calibration to default settings.</li> </ul> <p><b>Temperature offset:</b></p> <ul style="list-style-type: none"> <li>• xxx °C or °F</li> </ul>
<p><b>DT800</b></p>	<p>Enables setup and calibration of DT (Depth, and Temperature) smart transducers and provides the following options:</p> <ul style="list-style-type: none"> <li>• <b>DT800 details</b></li> <li>• <b>Depth offset</b></li> <li>• <b>Temperature offset</b></li> </ul>	<p><b>DT800 details</b> displays information about the installed transducer, Serial No. and Software version etc.</p> <p><b>Depth offset</b> allows you to set the offset distance so that the displayed depth reading represents the depth to the sea bed from either the keel or the waterline.</p> <ul style="list-style-type: none"> <li>• <b>Depth from:</b> <ul style="list-style-type: none"> <li>– Water line</li> <li>– Keel</li> <li>– Transducer</li> </ul> </li> <li>• <b>Offset:</b> <ul style="list-style-type: none"> <li>– 0 to 99 ft, m</li> </ul> </li> <li>• <b>About depth offset</b></li> </ul> <p><b>Temperature offset:</b></p> <ul style="list-style-type: none"> <li>• xxx °C or °F</li> </ul>

## User Preferences menu

The **User Preferences** menu enables you to customize the unit settings.

Menu item	Description	Options
<b>Time &amp; Date</b>	<p>These options enable you to customize the date and time format to your requirements. You can also specify a local time offset from Universal Time Constant (UTC), to compensate for any time zone difference.</p>	<p><b>Date format:</b></p> <ul style="list-style-type: none"> <li>• mm/dd/yy</li> <li>• dd/mm/yy</li> </ul> <p><b>Time format:</b></p> <ul style="list-style-type: none"> <li>• 12hr</li> <li>• 24hr</li> </ul> <p><b>Time offset:</b></p> <ul style="list-style-type: none"> <li>• -13 to +13 hours</li> </ul>
<b>Units</b>	<p>Enables you to specify the units used for the following key measurements:</p> <ul style="list-style-type: none"> <li>• <b>Speed</b></li> <li>• <b>Distance</b></li> <li>• <b>Depth</b></li> <li>• <b>Wind speed</b></li> <li>• <b>Temperature</b></li> <li>• <b>Flow rate</b></li> <li>• <b>Heading</b></li> <li>• <b>Pressure</b></li> <li>• <b>Volume</b></li> <li>• <b>Barometric</b></li> </ul>	<p><b>Speed:</b></p> <ul style="list-style-type: none"> <li>• kts — knots.</li> <li>• mph — miles per hour.</li> <li>• km/h — Kilometers per hour.</li> </ul> <p><b>Distance:</b></p> <ul style="list-style-type: none"> <li>• nm — Nautical miles.</li> <li>• sm — Statute miles.</li> <li>• km — Kilometers.</li> </ul> <p><b>Depth:</b></p> <ul style="list-style-type: none"> <li>• ft — Feet</li> <li>• m — Metres</li> <li>• fa — Fathoms</li> </ul> <p><b>Wind speed:</b></p> <ul style="list-style-type: none"> <li>• kts — knots.</li> <li>• m/s — metres per second.</li> </ul> <p><b>Temperature:</b></p> <ul style="list-style-type: none"> <li>• °C — degrees centigrade.</li> <li>• °F — degrees fahrenheit.</li> </ul> <p><b>Flow Rate</b></p> <ul style="list-style-type: none"> <li>• UK Gal/H — UK gallons per hour.</li> <li>• US Gal/H — US gallons per hour.</li> <li>• LPH — Liters per hour.</li> </ul> <p><b>Heading:</b></p> <ul style="list-style-type: none"> <li>• Mag — magnetic.</li> <li>• True</li> </ul> <p><b>Pressure</b></p> <ul style="list-style-type: none"> <li>• PSI — pounds per square inch.</li> <li>• Bar — bar.</li> <li>• kPa — Kilo pascals.</li> </ul> <p><b>Volume:</b></p> <ul style="list-style-type: none"> <li>• UK Gallons</li> <li>• US Gallons</li> <li>• ltr — liter.</li> </ul>

Menu item	Description	Options
<b>Language</b>	Determines the language that will be used for all on-screen text, labels, menus and options.	<ul style="list-style-type: none"> <li>• English (UK)</li> <li>• English (US)</li> <li>• Chinese</li> <li>• Croatian</li> <li>• Danish</li> <li>• Dutch</li> <li>• Finnish</li> <li>• French</li> <li>• German</li> <li>• Greek</li> <li>• Italian</li> <li>• Japanese</li> <li>• Korean</li> <li>• Norwegian</li> <li>• Polish</li> <li>• Portuguese (Brazilian)</li> <li>• Russian</li> <li>• Spanish</li> <li>• Swedish</li> <li>• Turkish</li> </ul>
<b>Boat Type</b>	Determines the default setup of the unit and favorite pages	<ul style="list-style-type: none"> <li>• Race Sail</li> <li>• Sail Cruiser</li> <li>• Catamaran</li> <li>• Workboat</li> <li>• RIB</li> <li>• Outboard Speedboat</li> <li>• Inboard Speedboat</li> <li>• Power Cruiser 1 (&lt;12kts)</li> <li>• Power Cruiser 2 (&lt;30kts)</li> <li>• Power Cruiser 3 (&gt;30kts)</li> <li>• Sport Fishing</li> <li>• Pro Fishing</li> </ul>
<b>Boat Details</b>	Enable you to specify the following: <ul style="list-style-type: none"> <li>• <b>Number of engines</b></li> <li>• <b>Number of batteries</b></li> <li>• <b>Number of fuel tanks</b></li> <li>• <b>Max RPM range</b></li> <li>• <b>RPM Red Zone</b></li> </ul>	<b>Number of engines:</b> <ul style="list-style-type: none"> <li>• 1 — 5</li> </ul> <b>Number of batteries</b> <ul style="list-style-type: none"> <li>• 1 — 5</li> </ul> <b>Number of fuel tanks</b> <ul style="list-style-type: none"> <li>• 1 — 5</li> </ul> <b>Max RPM range</b> <ul style="list-style-type: none"> <li>• Auto (default)</li> <li>• 3000 rpm</li> <li>• 4000 rpm</li> <li>• 5000 rpm</li> </ul>



Menu item	Description	Options
		<ul style="list-style-type: none"> <li>• 6000 rpm</li> <li>• 7000 rpm</li> <li>• 8000 rpm</li> <li>• 9000 rpm</li> <li>• 10000 rpm</li> </ul> <p><b>RPM Red Zone</b></p> <ul style="list-style-type: none"> <li>• Auto (default)</li> <li>• Custom value</li> </ul>
<b>Variation</b>	<p>Enables you to turn on and off magnetic variation, specify slave source or adjust manually.</p> <ul style="list-style-type: none"> <li>• <b>Variation mode</b></li> <li>• <b>Variation range</b></li> </ul>	<p><b>Variation mode:</b></p> <ul style="list-style-type: none"> <li>• On</li> <li>• Off (default)</li> <li>• Slave</li> </ul> <p><b>Variation range:</b></p> <ul style="list-style-type: none"> <li>• -30° — +30°</li> </ul>
<b>Key Beep</b>	<p>Enable and disable the audible beep when pressing buttons.</p>	<ul style="list-style-type: none"> <li>• On (default)</li> <li>• Off</li> </ul>

## System set-up menu

The **System set-up** menu enables users to customize the following user settings:

Menu item	Description	Options
<b>Network group</b>	Allows adding multiple units together in a group so that when the color scheme or brightness is changed on one unit the changes are applied to all units in the group.	<b>Predefined groups</b> <ul style="list-style-type: none"> <li>• None</li> <li>• Helm 1</li> <li>• Helm 2</li> <li>• Cockpit</li> <li>• Flybridge</li> <li>• Mast</li> </ul> <b>Undefined</b> <ul style="list-style-type: none"> <li>• Group-1 — Group-5</li> </ul>
<b>Brightness / color group</b>	Enables synchronization of the displays brightness and color to be the same as the other units in the same group.	<b>Sync brightness / color</b> <ul style="list-style-type: none"> <li>• This display</li> <li>• This group</li> </ul>
<b>Data sources</b>	Allows you to view and select preferred data sources. <ul style="list-style-type: none"> <li>• <b>Select data source</b></li> <li>• <b>Data source found</b></li> <li>• <b>Data source details</b></li> </ul>	<b>Select data source</b> <ul style="list-style-type: none"> <li>• GPS position</li> <li>• GPS Datum</li> <li>• Time &amp; Date</li> <li>• Heading</li> <li>• Depth</li> <li>• Speed</li> <li>• Wind</li> </ul> <b>Data source found</b> <ul style="list-style-type: none"> <li>• model name — serial number Port ID</li> </ul> <b>Data source details</b> <ul style="list-style-type: none"> <li>• Device name</li> <li>• Serial No.</li> <li>• Port ID</li> <li>• Status or No data</li> </ul>
<b>About system set-up</b>	Provides information about the System set-up menu.	

## Diagnostics menu

You can access diagnostics details from the **Diagnostics** menu: (**Menu > Set-up > Diagnostics**).

Menu item	Description	Options
<b>About display</b>	Allows you to view information about the display you are using:	<ul style="list-style-type: none"> <li>• Software version</li> <li>• Hardware version</li> <li>• Bootloader version</li> <li>• Temperature</li> <li>• Volts</li> <li>• Max. volts</li> <li>• Current</li> <li>• Max. current</li> <li>• Run time</li> <li>• Deviation (If available)</li> </ul>
<b>About Pilot</b>	Allows you to view information about the autopilot you are using: <div style="border: 1px solid black; padding: 5px; margin-top: 10px;"> <p><b>Note:</b> The <b>About Pilot</b> menu is only available on Pilot controllers.</p> </div>	<ul style="list-style-type: none"> <li>• NMEA Code</li> <li>• Product ID</li> <li>• Serial number</li> <li>• Description</li> <li>• Software version</li> <li>• PCB Number</li> <li>• CAN Volts</li> <li>• Unit Volts</li> <li>• Operating hours</li> <li>• Deviation</li> </ul>
<b>About system</b>	Allows you to search the <b>SeaTalk<sup>ng</sup></b> network and display information about the products found.	<ul style="list-style-type: none"> <li>• Model number</li> <li>• Serial number</li> <li>• Software version</li> <li>• Hardware version</li> <li>• Volts</li> </ul>
<b>Self test</b>	The product has a built in self test which can help to diagnose faults. Self-Test include: <ul style="list-style-type: none"> <li>• Memory test</li> <li>• Button test</li> <li>• Display test</li> <li>• Buzzer test</li> <li>• Illumination test</li> </ul>	N/A



# Chapter 14: Maintenance

## Chapter contents

- 14.1 Service and maintenance on page 86
- 14.2 Routine equipment checks on page 86
- 14.3 Product cleaning on page 87
- 14.4 Cleaning the display case on page 87
- 14.5 Cleaning the display screen on page 88
- 14.6 Cleaning the sun cover on page 88

## **14.1 Service and maintenance**

This product contains no user serviceable components. Please refer all maintenance and repair to authorized Raymarine dealers. Unauthorized repair may affect your warranty.

## **14.2 Routine equipment checks**

Raymarine strongly recommends that you complete a number of routine checks to ensure the correct and reliable operation of your equipment.

Complete the following checks on a regular basis:

- Examine all cables for signs of damage or wear and tear.
- Check that all cables are securely connected.

## 14.3 Product cleaning

Best cleaning practices.

When cleaning products:

- If your product includes a display screen, do NOT wipe the screen with a dry cloth, as this could scratch the screen coating.
- Do NOT use abrasive, or acid or ammonia based products.
- Do NOT use a jet wash.

## 14.4 Cleaning the display case

The display unit is a sealed unit and does not require regular cleaning. If it is necessary to clean the unit, follow this basic procedure:

1. Switch off the power to the display.
2. Wipe the display with a clean, soft cloth (a microfibre cloth is ideal).
3. If necessary, use a mild detergent to remove grease marks.

**Note:** Do NOT use solvents or detergents on the screen itself.

**Note:** In certain conditions, condensation may appear inside the display screen. This will not harm the unit, and can be cleared by powering on the display for a short time.

## 14.5 Cleaning the display screen

A coating is applied to the display screen. This makes it water repellent, and prevents glare. To avoid damaging this coating, follow this procedure:

1. Switch off the power to the display.
2. Rinse the screen with fresh water to remove all dirt particles and salt deposits.
3. Allow the screen to dry naturally.
4. If any smears remain, very gently wipe the screen with a clean microfibre cleaning cloth (available from an opticians).

## Transducer care and cleaning

Growth can collect on the bottom of the transducer, this can reduce performance. To prevent the build-up of sea growth, coat the transducer with a thin layer of water-based antifouling paint, available from your local marine dealer. Reapply paint every 6 months or at the beginning of each boating season. Certain smart transducers have restrictions on where antifouling paint is applied. Please consult your dealer.

**Note:** Transducers with a temperature sensor may not work properly if painted.

**Note:** Never use ketone-based paint. Ketones can attack many plastics, possibly damaging the sensor.

**Note:** Never use spray paint on your transducer. Spraying incorporates tiny air bubbles, and a marine transducer cannot transmit properly through air.

Use a soft cloth and mild household detergent to clean the transducer. If the fouling is severe, remove the growth with a tough cleaning pad, such as a green Scotch Brite™ pad for example. Be careful to avoid scratching the face of the transducer.

**Note:** Harsh cleaning solvents such as acetone WILL damage the transducer.

## 14.6 Cleaning the sun cover

The supplied sun cover features an adhesive surface. In certain conditions unwanted contaminants may stick to this surface. To avoid damaging the monitor display, clean the sun cover regularly following this procedure:

1. Carefully remove the sun cover from the display.
2. Rinse the sun cover with fresh water to remove all dirt particles and salt deposits.
3. Allow the sun cover to dry naturally.



# Chapter 15: System checks and troubleshooting

## Chapter contents

- [15.1 Troubleshooting on page 90](#)
- [15.2 Power up troubleshooting on page 91](#)
- [15.3 System data troubleshooting on page 92](#)
- [15.4 Miscellaneous troubleshooting on page 93](#)
- [15.5 Performing a Factory Reset on page 94](#)

## 15.1 Troubleshooting

The troubleshooting information provides possible causes and corrective action required for common problems associated with marine electronics installations.

All Raymarine products are, prior to packing and shipping, subjected to comprehensive test and quality assurance programs. However, if you experience problems with the operation of your product this section will help you to diagnose and correct problems in order to restore normal operation.

If after referring to this section you are still having problems with your unit, please contact Raymarine Technical Support for further advice.

## 15.2 Power up troubleshooting

Problems at power up and their possible causes and solutions are described here.

### Product does not turn on or keeps turning off

Possible causes	Possible solutions
Blown fuse / tripped breaker	<ol style="list-style-type: none"> <li>1. Check condition of relevant fuses and breakers and connections, replace if necessary (Refer to the <i>Technical Specification</i> section of your product's installation instructions for fuse ratings.)</li> <li>2. If fuse keeps blowing check for cable damage, broken connector pins or incorrect wiring.</li> </ol>
Poor / damaged / insecure power supply cable / connections	<ol style="list-style-type: none"> <li>1. Check that the power cable connector is fully inserted into the unit and locked in position.</li> <li>2. Check the power supply cable and connectors for signs of damage or corrosion, replace if necessary.</li> <li>3. With the unit turned on, try flexing the power cable near to the display connector to see if this causes the unit to re-boot/loose power, replace if necessary.</li> <li>4. Check the vessel's battery voltage, the condition of the battery terminals and power supply cables, ensuring connections are secure, clean and free from corrosion, replace if necessary.</li> <li>5. With the product under load, using a multi-meter, check for high voltage drop across all connectors/fuses etc, replace if necessary.</li> </ol>
Incorrect power connection	The power supply may be wired incorrectly, ensure the installation instructions have been followed.
Power source insufficient	With the product under load, using a multi-meter, check the power supply voltage as close to the unit as possible to establish actual voltage when the current is flowing. (Refer to the <i>Technical Specification</i> section of your product's installation instructions for power supply requirements.)

### Product will not boot up (re-boot loop)

Possible causes	Possible solutions
Power supply and connection	See possible solutions from 'Products does not turn on or keeps turning off' above.
Software corruption	<ol style="list-style-type: none"> <li>1. In the unlikely event that the products software has become corrupted please try re-flashing the latest software from the Raymarine website.</li> <li>2. On display products, as a last resort, you can try to perform a 'Power on Reset', however this will delete all settings/presets and user data (such as waypoints and tracks) and revert the unit back to factory defaults.</li> </ol>

## 15.3 System data troubleshooting

Aspects of the installation can cause problems with the data shared between connected equipment. Such problems, their possible causes and solutions are described here.

Problem	Possible causes	Possible solutions
Instrument, engine or other system data is unavailable at all displays.	Data is not being received at the display.	Check the data bus (e.g. <b>SeaTalk<sup>ng</sup></b> ) wiring and connections.
		Check the overall integrity of the data bus (e.g. <b>SeaTalk<sup>ng</sup></b> ) wiring.
		If available refer to the reference guide for the data bus (e.g. <b>SeaTalk<sup>ng</sup></b> reference manual).
	Data source (e.g. instrument display or engine interface) is not operating.	Check the source of the missing data (e.g. instrument display or engine interface).
		Check the power to the <b>SeaTalk</b> bus.
		Refer to the manufacturer's handbook for the equipment in question.
Software mismatch between equipment may prevent communication.	Contact Raymarine technical support.	
Instrument or other system data is missing from some but not all displays.	Network problem.	Check that all required equipment is connected to the network.
		Check the status of the Raymarine network Switch.
		Check that <b>SeaTalk<sup>hs</sup></b> / <b>RayNet</b> cables are free from damage.
	Software mismatch between equipment may prevent communication.	Contact Raymarine technical support.
Position data is not displayed on VHF radio	VHF radio <b>NMEA 0183</b> input not isolated / incorrect polarity	<ul style="list-style-type: none"> <li>• Check that the radio has an Isolated <b>NMEA 0183</b> input.</li> <li>• Check polarity of <b>NMEA 0183</b> wires.</li> </ul>

## 15.4 Miscellaneous troubleshooting

Miscellaneous problems and their possible causes and solutions are described here.

Problem	Possible causes	Possible solutions
Display behaves erratically: <ul style="list-style-type: none"> <li>• Frequent unexpected resets.</li> <li>• System crashes or other erratic behavior.</li> </ul>	Intermittent problem with power to the display.	Check relevant fuses and breakers.
		Check that the power supply cable is sound and that all connections are tight and free from corrosion.
		Check that the power source is of the correct voltage and sufficient current.
	Software mismatch on system (upgrade required).	Go to <a href="http://www.raymarine.com">www.raymarine.com</a> and click on support for the latest software downloads.
Corrupt data / other unknown issue.	Perform a factory reset.	<div style="border: 1px solid black; padding: 5px;"> <p><b>Important:</b> This will result in the loss of any settings and data (such as waypoints) stored on the product. Save any important data to a memory card before resetting.</p> </div>

## 15.5 Performing a Factory Reset

To reset your unit to factory default settings follow the steps below.

**Note:** Performing a factory reset will erase all saved data and customized settings.

1. Press the **Menu** button.
2. Select **Set Up**.
3. Select **Factory Reset**.
4. Select **Yes**.

Your unit will now reset itself to factory default settings.

## Chapter 16: Technical support

### Chapter contents

- [16.1 Raymarine product support and servicing on page 96](#)
- [16.2 Viewing product information on page 97](#)

## 16.1 Raymarine product support and servicing

Raymarine provides a comprehensive product support service, as well as warranty, service, and repairs. You can access these services through the Raymarine website, telephone, and e-mail.

### Product information

If you need to request service or support, please have the following information to hand:

- Product name.
- Product identity.
- Serial number.
- Software application version.
- System diagrams.

You can obtain this product information using the menus within your product.

### Servicing and warranty

Raymarine offers dedicated service departments for warranty, service, and repairs.

Don't forget to visit the Raymarine website to register your product for extended warranty benefits: <http://www.raymarine.co.uk/display/?id=788>.

Region	Tele-phone	E-mail
United Kingdom (UK), EMEA, and Asia Pacific	+44 (0)1329 246 932	<a href="mailto:emea.service@raymarine.com">emea.service@raymarine.com</a>
United States (US)	+1 (603) 324 7900	<a href="mailto:rm-usrepair@flir.com">rm-usrepair@flir.com</a>

### Web support

Please visit the "Support" area of the Raymarine website for:

- **Manuals and Documents** — <http://www.raymarine.com/manuals>
- **FAQ / Knowledgebase** — <http://www.raymarine.com/knowledgebase>
- **Technical support forum** — <http://forum.raymarine.com>
- **Software updates** — <http://www.raymarine.com/software>

### Telephone and e-mail support

Region	Tele-phone	E-mail
United Kingdom (UK), EMEA, and Asia Pacific	+44 (0)1329 246 777	<a href="mailto:support.uk@raymarine.com">support.uk@raymarine.com</a>
United States (US)	+1 (603) 324 7900 (Toll-free: +800 539 5539)	<a href="mailto:support@raymarine.com">support@raymarine.com</a>

Region	Tele-phone	E-mail
Australia and New Zealand	+61 2 8977 0300	<a href="mailto:aus.support@raymarine.com">aus.support@raymarine.com</a> (Raymarine subsidiary)
France	+33 (0)1 46 49 72 30	<a href="mailto:support.fr@raymarine.com">support.fr@raymarine.com</a> (Raymarine subsidiary)
Germany	+49 (0)40 237 808 0	<a href="mailto:support.de@raymarine.com">support.de@raymarine.com</a> (Raymarine subsidiary)
Italy	+39 02 9945 1001	<a href="mailto:support.it@raymarine.com">support.it@raymarine.com</a> (Raymarine subsidiary)
Spain	+34 96 2965 102	<a href="mailto:sat@azimut.es">sat@azimut.es</a> (Authorized Raymarine distributor)
Netherlands	+31 (0)26 3614 905	<a href="mailto:support.nl@raymarine.com">support.nl@raymarine.com</a> (Raymarine subsidiary)
Sweden	+46 (0)317 633 670	<a href="mailto:support.se@raymarine.com">support.se@raymarine.com</a> (Raymarine subsidiary)
Finland	+358 (0)207 619 937	<a href="mailto:support.fi@raymarine.com">support.fi@raymarine.com</a> (Raymarine subsidiary)
Norway	+47 692 64 600	<a href="mailto:support.no@raymarine.com">support.no@raymarine.com</a> (Raymarine subsidiary)
Denmark	+45 437 164 64	<a href="mailto:support.dk@raymarine.com">support.dk@raymarine.com</a> (Raymarine subsidiary)
Russia	+7 495 788 0508	<a href="mailto:info@mikstmarine.ru">info@mikstmarine.ru</a> (Authorized Raymarine distributor)



## 16.2 Viewing product information

1. Press the **Menu** button.
2. Select **Set-up**.
3. Select **Diagnostics**.
4. Select **About Display**.

A range of information is displayed, including the software version and Serial number.

5. Use the **Up** and **Down** buttons to cycle through the information.



# Chapter 17: Technical specification

## Chapter contents

- [17.1 Technical specification on page 100](#)

## 17.1 Technical specification

Nominal supply voltage	12 V dc
Operating voltage range	9 to 16 V dc
Current	132 mA
Power consumption	1.6 W
LEN (Refer to the SeaTalk <sup>ng</sup> reference manual for further information.)	3
Environmental	Operating temperature: -25°C to 55°C (-13°F to 131°F) Storage temperature range: -30°C to 70°C (-22°F to 158°F) Relative humidity: max: 93% Water proof to IPX6
Display screen	TFT LCD display, 16bit color (64k colors) Resolution: 320x240 Brightness: 700 cd/m <sup>2</sup>
Data connections	2 x SeaTalk <sup>ng</sup> ports (fulling compliant with NMEA2000 & SeaTalk specifications).
Conformance	<ul style="list-style-type: none"><li>• Europe 2004/108/EC</li><li>• Australia and New Zealand C-Tick, compliance level 2</li></ul>

# Chapter 18: Options and accessories

## Chapter contents

- 18.1 Spares and accessories on page 102
- 18.2 Smart transducers on page 102
- 18.3 Instrument Depth, Speed and Temperature (DST) transducers on page 103
- 18.4 Instrument Depth transducers on page 104
- 18.5 Instrument Speed and Temperature transducers on page 104
- 18.6 Instrument Wind Vane transducer on page 105
- 18.7 Instrument Rotavecta transducer on page 105
- 18.8 Other transducers on page 106
- 18.9 SeaTalk<sup>ng</sup>® cables and accessories on page 106
- 18.10 SeaTalk<sup>ng</sup> cable kits on page 108
- 18.11 SeaTalk accessories on page 111

## 18.1 Spares and accessories

Part number	Description
R22168	Spare bezel
R22169	Sun cover

## 18.2 Smart transducers

Smart transducers can be connected directly to the **SeaTalk<sup>ng</sup>**® backbone without the need for an **iTC-5** or transducer pod.

The smart transducers listed below are compatible with the following displays:

- **i70 / i70s**
- Multifunction displays

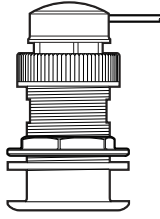
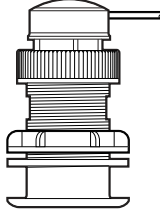
Part number	Image	Mounting	Type
A22147		Thru-Hull	DT800-12 Bronze
A80374 (replaces A22112)		Thru-Hull	DT800-12 Plastic

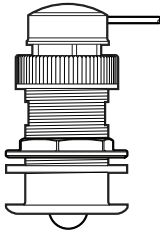
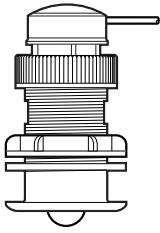
Part number	Image	Mounting	Type
A22146		Thru-Hull	DST800 Bronze
A80375 (replaces A22111)		Thru-Hull	DST800 Plastic

## 18.3 Instrument Depth, Speed and Temperature (DST) transducers

The DST transducers listed below are compatible with the following instrument displays:

- **i40** Depth / **i40** Speed / **i40** Bidata
- **i50** Depth **i50** Speed / **i50** Tridata
- **i70** / **i70s** via **iTC-5** converter

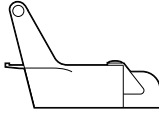
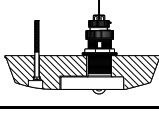
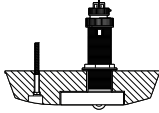
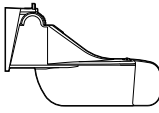
Part number	Image	Mounting	Housing
E26006-PZ		Transom mount	P66 / ST40
A26043		Thru-hull	B744V (including fairing block)
A26044		Thru-hull	B744VL (including fairing block)
E26028-PZ		Transom mount	P66

## 18.4 Instrument Depth transducers

The depth transducers listed below are compatible with the following instrument displays:

- **i40** Depth / **i40** Bidata
- **i50** Depth / **i50** Tridata
- **i70** / **i70s** via **iTC-5** converter

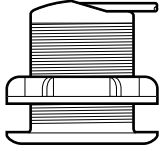
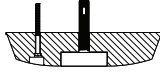
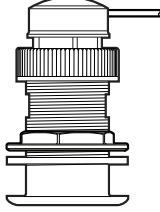
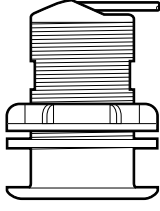
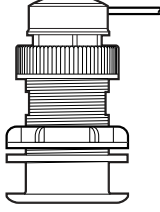
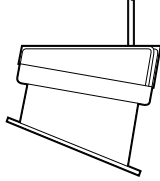
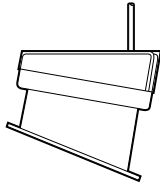
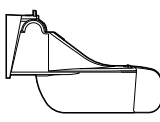
Part number	Image	Mounting	Housing
E26009		Thru-hull	P7
E26019-PZ		Thru-hull	B45 (including fairing block)
M78717		Thru-hull	B17
M78713-PZ		Thru-hull	P319
E26030		Thru-hull	P17
E26001-PZ		In-hull	P79
A80373 T70278 — (includes SeaTalkng adaptor)		In-hull	P79S
E26027-PZ		Transom mount	P66

## 18.5 Instrument Speed and Temperature transducers

The speed and temperature transducers listed below are compatible with the following instrument displays:

- **i40** Speed / **i40** Bidata
- **i50** Speed / **i50** Tridata
- **i70** / **i70s** via **iTC-5** converter

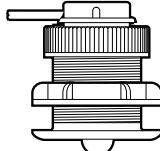
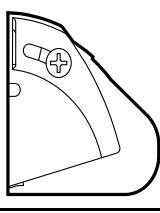
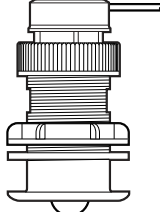
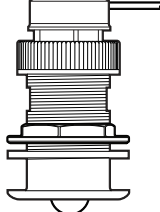
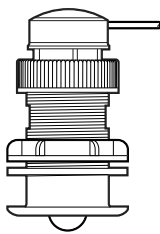
Part number	Image	Mounting	Housing
E26008		Thru-hull	P371
E26005		Transom mount	ST69
E26031		Thru-hull	P120 / ST800
M78716		Thru-hull	B120
E25025		Thru-hull	P17



## 18.6 Instrument Wind Vane transducer

The wind vane transducers listed below are compatible with the following instrument displays:

- **i60** Wind
- **i70 / i70s** via **iTC-5** converter

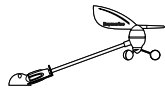
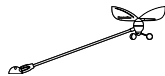
Part number	Image	Housing	Mounting
E22078		Short arm wind vane	Surface mount
E22079		Long arm wind vane	Surface mount

## 18.7 Instrument Rotavecta transducer

The wind transducers listed below are compatible with the following instrument displays:

- **i40** Wind
- **i60** Wind
- **i70 / i70s** via **iTC-5** converter

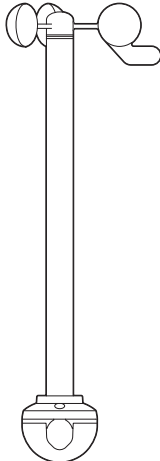
Part number	Image	Housing	Mounting
Z195		Rotavecta transducer	Surface mount

## 18.8 Other transducers

When connected using an **iTC-5**, the transducers listed below are compatible with the your **i70 / i70s** display:

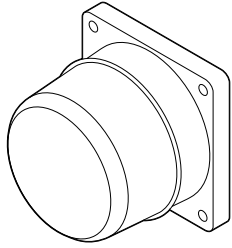
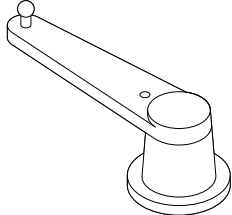
Part number	Image	Type
M81190		Fluxgate compass
M81105		Rudder Reference

## 18.9 SeaTalk<sup>ng</sup>® cables and accessories



SeaTalk<sup>ng</sup> cables and accessories for use with compatible products.

Description	Part No	Notes
SeaTalk <sup>ng</sup> starter kit	T70134	Includes: <ul style="list-style-type: none"> <li>• 1 x 5 Way connector (A06064)</li> <li>• 2 x Backbone terminator (A06031)</li> <li>• 1 x 3 m (9.8ft) spur cable (A06040)</li> <li>• 1 x Power cable (A06049)</li> </ul>
SeaTalk <sup>ng</sup> Backbone Kit	A25062	Includes: <ul style="list-style-type: none"> <li>• 2 x 5m (16.4ft) Backbone cable (A06036)</li> <li>• 1 x 20m (65.6ft) Backbone cable (A06037)</li> <li>• 4 x T-piece (A06028)</li> <li>• 2 x Backbone terminator (A06031)</li> <li>• 1 x Power cable (A06049)</li> </ul>
SeaTalk <sup>ng</sup> 0.4m (1.3ft) spur	A06038	
SeaTalk <sup>ng</sup> 1 m (3.3ft) spur	A06039	
SeaTalk <sup>ng</sup> 3 m (9.8ft) spur	A06040	
SeaTalk <sup>ng</sup> 5 m (16.4ft) spur	A06041	
SeaTalk <sup>ng</sup> 0.4 m (1.3 ft) elbow spur	A06042	
SeaTalk <sup>ng</sup> 0.4m (1.3ft) backbone	A06033	
SeaTalk <sup>ng</sup> 1 m (3.3ft) backbone	A06034	
SeaTalk <sup>ng</sup> 3 m (9.8ft) backbone	A06035	
SeaTalk <sup>ng</sup> 5 m (16.4ft) backbone	A06036	
SeaTalk <sup>ng</sup> 9 m (29.5ft) backbone	A06068	
SeaTalk <sup>ng</sup> 20 m (65.6ft) backbone	A06037	
SeaTalk <sup>ng</sup> to bare ends 1 m (3.3ft) spur	A06043	





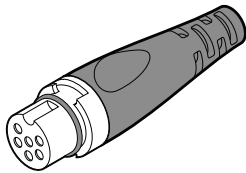

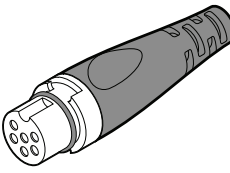
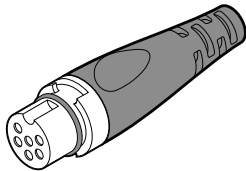
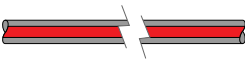
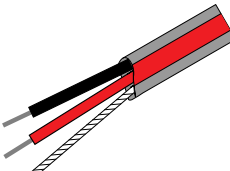
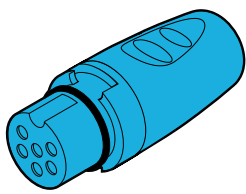
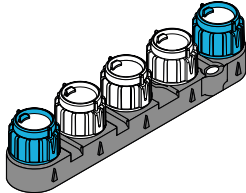
Description	Part No	Notes
SeaTalk <sup>ng</sup> to bare ends 3 m (9.8ft) spur	A06044	
SeaTalk <sup>ng</sup> Power cable	A06049	
SeaTalk <sup>ng</sup> Terminator	A06031	
SeaTalk <sup>ng</sup> T-piece	A06028	Provides 1 x spur connection
SeaTalk <sup>ng</sup> 5-way connector	A06064	Provides 3 x spur connections
SeaTalk <sup>ng</sup> backbone extender	A06030	
SeaTalk to SeaTalk <sup>ng</sup> converter kit	E22158	Allows the connection of SeaTalk devices to a SeaTalk <sup>ng</sup> system.
SeaTalk <sup>ng</sup> Inline terminator	A80001	Provides direct connection of a spur cable to the end of a backbone cable. No T-piece required.
SeaTalk <sup>ng</sup> Blanking plug	A06032	
ACU / SPX SeaTalk <sup>ng</sup> spur cable 0.3 m (1.0 ft)	R12112	Connects an SPX course computer or an ACU to a SeaTalk <sup>ng</sup> backbone.
SeaTalk (3 pin) to SeaTalk <sup>ng</sup> adaptor cable 0.4m (1.3ft)	A06047	
SeaTalk to SeaTalk <sup>ng</sup> spur 1 m (3.3ft) spur	A22164	
SeaTalk2 (5 pin) to SeaTalk <sup>ng</sup> adaptor cable 0.4m (1.3ft)	A06048	
DeviceNet adaptor cable (Female)	A06045	Allows the connection of NMEA 2000 devices to a SeaTalk <sup>ng</sup> system.
DeviceNet adaptor cable (Male)	A06046	Allows the connection of NMEA 2000 devices to a SeaTalk <sup>ng</sup> system.
DeviceNet adaptor cable (Female) to bare ends.	E05026	Allows the connection of NMEA 2000 devices to a SeaTalk <sup>ng</sup> system.
DeviceNet adaptor cable (Male) to bare ends.	E05027	Allows the connection of NMEA 2000 devices to a SeaTalk <sup>ng</sup> system.

## 18.10 SeaTalk<sup>ng</sup> cable kits

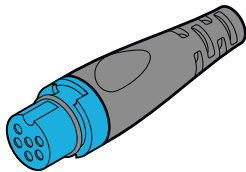
### SeaTalk<sup>ng</sup> starter kit (T70134)

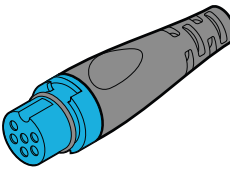
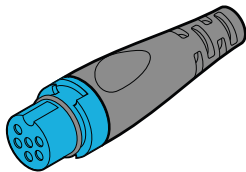
Parts included	Quantity	Connector A	Cable	Connector B	Length
Spur cable (A06040)	1				3m (9.8ft)
Power cable (A06049)	1				1m (3.3ft)
Backbone terminator (A06031)	2		N/A	N/A	N/A
5-way connector (A06064). Each connector block allows the connection of up to 3 compatible devices. When correctly terminated, a connector block forms a complete backbone. Multiple connector blocks can be daisy-chained together.	1		N/A	N/A	N/A

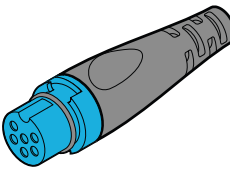
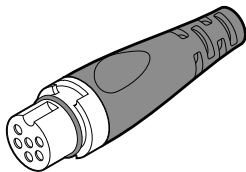
### SeaTalk<sup>ng</sup> Backbone kit (A25062)

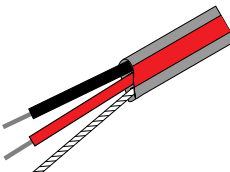
Parts included	Quantity	Connector A	Cable	Connector B	Length
Backbone cable ((A06036))	2				5m (16.4ft)
Backbone cable ((A06037))	1				20m (65.6ft)
Power cable (A06049)	1				1m (3.3ft)



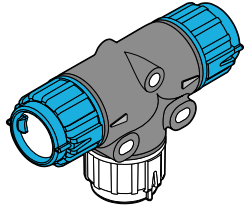
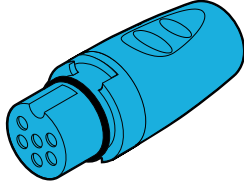

Parts included	Quantity	Connector A	Cable	Connector B	Length
T-piece (A06028)	4		N/A	N/A	N/A
Backbone terminator (A06031)	2		N/A	N/A	N/A

**SeaTalk<sup>ng</sup> Evolution cable kit (R70160)**

Parts included	Quantity	Connector A	Cable	Connector B	Length
Backbone cable (A06036)	2				5m (16.4ft)
Power cable (A06049)	1				1m (3.3ft)
Spur cable (A06040)	1				1m (3.3ft)
ACU / SPX power cable (R12112) (for powering the SeaTalk <sup>ng</sup> backbone from the autopilot system.	1				0.3m (1.0ft)
5-way connector (A06064). Each connector block allows the connection of up to 3 compatible devices. When correctly terminated, a connector block forms a complete backbone. Multiple connector blocks can be daisy-chained together.	1		N/A	N/A	N/A

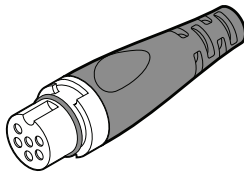
Parts included	Quantity	Connector A	Cable	Connector B	Length
T-piece (A06028)	2		N/A	N/A	N/A
Backbone terminator (A06031)	2		N/A	N/A	N/A

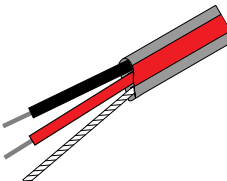
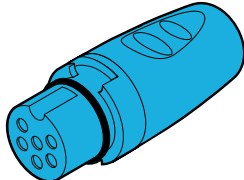
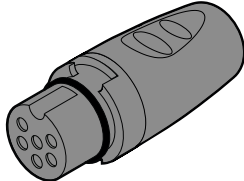
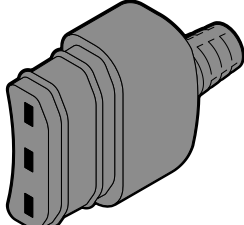
### SeaTalk<sup>ng</sup> converter kit (E22158)

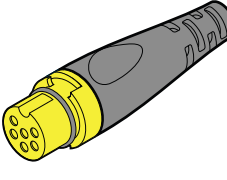
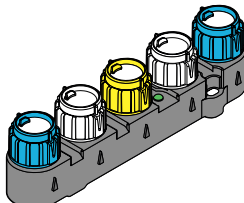
Parts included	Quantity	Connector A	Cable	Connector B	Length
Power cable (A06049)	1				1m (3.3ft)
Backbone terminator (A06031)	2		N/A	N/A	N/A
Blanking plug (A06032)			N/A	N/A	N/A
SeaTalk (3 pin) adapter cable (A06047)	1				0.4m (1.3ft)
SeaTalk to SeaTalk <sup>ng</sup> converter (E22158). Enables the connection of SeaTalk devices to a SeaTalk <sup>ng</sup> system.	1		N/A	N/A	N/A

## 18.11 SeaTalk accessories

SeaTalk cables and accessories for use with compatible products.

Description	Part No	Notes
3-way SeaTalk junction box	D244	
1 m (3.28 ft) SeaTalk extension cable	D284	
3 m (9.8ft) SeaTalk extension cable	D285	
5 m (16.4ft) SeaTalk extension cable	D286	
9 m (29.5ft) SeaTalk extension cable	D287	
12 m (39.4ft) SeaTalk extension cable	E25051	
20 m (65.6ft) SeaTalk extension cable	D288	





## Appendix A Supported NMEA 2000 PGN list

PGN	Description	Received	Transmitted
59392	ISO Acknowledgment	•	•
59904	ISO Request	•	
60928	ISO Address Claim	•	•
126208	NMEA - Request group function	•	•
126464	PGN List – Receive / Transmit PGN's Group function	•	•
126992	System Time	•	•
126996	Product Information	•	•
127237	Heading/Track Control	•	
127245	Rudder	•	•
127250	Vessel Heading	•	•
127251	Rate of Turn	•	•
127257	Attitude	•	
127258	Magnetic Variation	•	•
127488	Engine Parameters, Rapid Update	•	
127489	Engine Parameters, Dynamic	•	
127493	Transmission Parameters, Dynamic	•	
127496	Trip Parameters, Vessel	•	
127497	Trip Parameters, Engine	•	
127498	Engine Parameters, Static	•	
127505	Fluid Level	•	
127508	Battery Status	•	
128259	Speed	•	•
128267	Water Depth (below transducer)	•	•
128275	Distance Log	•	•
129025	Position, Rapid Update	•	•
129026	COG & SOG, Rapid Update	•	•
129029	GNSS Position Data	•	•
129033	Time & Date	•	•
129038	AIS Class A Position Report	•	

PGN	Description	Received	Transmitted
129039	AIS Class B Position Report	•	
129040	AIS Class B Extended Position Report	•	
129041	AIS Aids to Navigation	•	
129044	Datum	•	•
129283	Cross Track Error	•	•
129284	Navigation Data	•	•
129291	Set & Drift, Rapid Update	•	
129801	AIS Addressed Safety Related Message	•	
129802	AIS Safety Related Broadcast Message	•	
129809	AIS Class B CS Static Data Report Pt A	•	
129810	AIS Class B CS Static Data Report Pt B	•	
130306	Wind Data	•	•
130310	Environmental Parameters	•	•
130311	Environmental Parameters	•	•
130576	Small Craft Status	•	
130577	Direction Data	•	



**Raymarine<sup>®</sup>**  
BY  **FLIR<sup>®</sup>**



[www.raymarine.com](http://www.raymarine.com)

